

# **Design Manual For Structural Stainless Steel**

**(Third Edition)**

© 2006 Euro Inox and The Steel Construction Institute

ISBN 2-87997-204-3

(Second edition 2002: ISBN 2-87997-037-7)

Euro Inox and The Steel Construction Institute have made every effort to ensure that the information presented here is technically correct. However, the reader is advised that the material contained therein is for general information purposes only. Euro Inox, The Steel Construction Institute and any other contributor specifically disclaim any liability or responsibility for loss, damage or injury, resulting from the use of the information contained in this publication.

CD-ROM, 7 languages	ISBN 2-87997-187-X
Finnish version	ISBN 2-87997-208-6
French version	ISBN 2-87997-205-1
German version	ISBN 2-87997-210-8
Italian version	ISBN 2-87997-206-X
Spanish version	ISBN 2-87997-207-8
Swedish version	ISBN 2-87997-209-4

# PREFACE

## Third Edition

This Third Edition of the Design Manual has been prepared by The Steel Construction Institute as a deliverable of the RFCS Project - *Valorisation Project – Structural design of cold worked austenitic stainless steel* (contract RFS2-CT-2005-00036). It is a complete revision of the Second Edition, extending the scope to include cold worked austenitic stainless steels and updating all the references to draft Eurocodes. The Third Edition refers to the relevant parts of EN 1990, EN 1991 and EN 1993. The structural fire design approach in Section 7 has been updated and new sections on the durability of stainless steel in soil and life cycle costing have been added.

Three new design examples have been included to demonstrate the appropriate use of cold worked stainless steel. They were completed by the following partners:

- Universitat Politècnica de Catalunya (UPC)
- The Swedish Institute of Steel Construction (SBI)
- Technical Research Centre of Finland (VTT)

A project steering committee, including representatives from each partner and sponsoring organisation, oversaw the work and contributed to the development of the Design Manual. The following organizations participated in the preparation of the Third Edition:

- The Steel Construction Institute (SCI) (Project co-ordinator)
- Centro Sviluppo Materiali (CSM)
- CUST, Blaise Pascal University
- Euro Inox
- RWTH Aachen, Institute of Steel Construction
- VTT Technical Research Centre of Finland
- The Swedish Institute of Steel Construction (SBI)
- Universitat Politècnica de Catalunya (UPC)

## Preface to the Second Edition

This Design Manual has been prepared by The Steel Construction Institute as a deliverable of the ECSC funded project, *Valorisation Project – Development of the use of stainless steel in construction* (contract 7215-PP-056). It is a complete revision of the *Design manual for structural stainless steel*, which was prepared by The Steel Construction Institute between 1989 and 1992 and published by Euro Inox in 1994.

This new edition takes into account advances in understanding in the structural behaviour of stainless steel over the last 10 years. In particular, it includes the new design recommendations from the recently completed ECSC funded project, *Development of the use of stainless steel in construction* (contract 7210-SA/842), which has led to the scope of the Manual being extended to cover circular hollow sections and fire resistant design. Over the last ten years a great many new European standards have been issued covering

stainless steel material, fasteners, fabrication, erection, welding etc. The Manual has been updated to make reference to current standards and data in these standards.

A project steering committee, including representatives from each partner, sub-contractor and sponsoring organisation, oversaw the work and contributed to the development of the Manual.

The worked examples were completed by the following partners:

- Centre Technique Industriel de la Construction Métallique (CTICM)
- Luleå Institute of Technology
- RWTH Aachen
- VTT Technical Research Centre of Finland
- The Steel Construction Institute (SCI)

The following people were members of the steering committee and/or completed the design examples:

Nancy Baddoo	The Steel Construction Institute
Massimo Barteri	Centro Sviluppo Materiali (CSM)
Bassam Burgan	The Steel Construction Institute
Helena Burstrand Knutsson	The Swedish Institute of Steel Construction (SBI)
Lars Hamrebjörk	The Swedish Institute of Steel Construction (SBI)
Jouko Kouhi	VTT Technical Research Centre of Finland
Roland Martland	Health and Safety Executive (UK)
Enrique Mirambell	Universitat Politècnica de Catalunya (UPC)
Anders Olsson	AvestaPolarit AB ( <i>formerly</i> , Luleå Inst. of Technology)
Thomas Pauly	Euro Inox
Esther Real	Universitat Politècnica de Catalunya (UPC)
Ivor Ryan	Centre Technique Industriel de la Construction Métallique
Heiko Stangenberg	RWTH Aachen Institute of Steel Construction
Asko Talja	VTT Technical Research Centre of Finland

## ACKNOWLEDGEMENTS

The following organisations provided financial support for this edition of the Design Manual and their assistance is gratefully acknowledged:

- Research Fund for Coal and Steel (RFCS) (*formerly*, European Coal and Steel Community (ECSC))
- Euro Inox

The contribution made to this and the previous two editions by the European stainless steel producers and other organisations is also gratefully acknowledged.

# FOREWORD

This Design Manual has been prepared for the guidance of engineers experienced in the design of carbon steel structural steelwork though not necessarily in stainless steel structures. It is not in any way intended to have a legal status or absolve the engineer of responsibility to ensure that a safe and functional structure results.

The Manual is divided into two parts:

- Part I - Recommendations
- Part II - Design Examples

The Recommendations in Part I are formulated in terms of limit state philosophy and, where appropriate, are in compliance with the following Parts of Eurocode 3 *Design of steel structures*:

EN 1993-1-1 *Design of steel structures: General rules and rules for buildings*

EN 1993-1-2 *Design of steel structures: Structural fire design*

EN 1993-1-3 *Design of steel structures: General rules: Supplementary rules for cold-formed members and sheeting*

EN 1993-1-4 *Design of steel structures: General rules: Supplementary rules for stainless steels*

EN 1993-1-5 *Design of steel structures: Plated structural elements*

EN 1993-1-8 *Design of steel structures: Design of joints*

EN 1993-1-9 *Design of steel structures: Fatigue*

EN 1993-1-10 *Design of steel structures: Material toughness and through-thickness properties*

This Design Manual gives recommended values for certain factors. These values may be subject to modification at a national level by the National Annexes.

The Design Examples contained in Part II demonstrate the use of the recommendations. A cross-reference system locates that section of the examples corresponding to a particular recommendation.

The Recommendations and Design Examples are available online at Steelbiz, an SCI technical information system ([www.steelbiz.org](http://www.steelbiz.org)), and from the Euro Inox web site ([www.euro-inox.org](http://www.euro-inox.org)). A Commentary to the Recommendations, which includes a full set of references, is also available online at these web sites. The purpose of the Commentary is to allow the designer to assess the basis of the recommendations and to facilitate the development of revisions as and when new data become available. Opportunity is taken to present the results of various test programmes conducted specifically to provide background data for the Design Manual. The Recommendations, Design Examples and Commentary are also available on CD from Euro Inox.

An online design facility is available at [www.steel-stainless.org/software](http://www.steel-stainless.org/software) for designing cold-formed stainless steel members subject to axial tension, bending or axial compression. The design facility calculates section properties and member resistances in accordance with the Recommendations in this Design Manual.

The design recommendations presented in this document are based upon the best knowledge available at the time of publication. However, no responsibility of any kind for injury, death, loss, damage or delay, however caused, resulting from the use of the recommendations can be accepted by the project partners or others associated with its preparation.

# Contents

	<b>Page No.</b>
PREFACE	iii
ACKNOWLEDGEMENTS	iii
FOREWORD	v
<b>PART I – RECOMMENDATIONS</b>	
1 INTRODUCTION	1
1.1 Scope	1
1.2 Symbols	1
1.3 Conventions for member axes	3
1.4 Units	4
2 BASIS OF DESIGN	5
2.1 General requirements	5
2.2 Limit state design	5
2.3 Loading	7
3 MATERIALS: PROPERTIES, SELECTION AND DURABILITY	11
3.1 Material grades	11
3.2 Mechanical behaviour and design values of properties	16
3.3 Physical properties	21
3.4 Effects of temperature	21
3.5 Life cycle costing	22
3.6 Selection of materials	23
3.7 Durability	25
4 PROPERTIES OF SECTIONS	34
4.1 General	34
4.2 Maximum width-to-thickness ratios	34
4.3 Classification of cross-sections	34
4.4 Effective widths	38
4.5 Stiffened elements	43
4.6 Calculation of section properties	46
4.7 Resistances of cross-sections	49
5 MEMBER DESIGN	54
5.1 Introduction	54
5.2 Tension members	54
5.3 Compression members	54
5.4 Flexural members	58
5.5 Members subject to combinations of axial load and bending moments	68
6 JOINT DESIGN	71
6.1 General recommendations	71
6.2 Bolted connections	73

6.3	Mechanical fasteners for thin gauge material	78
6.4	Welded connections	78
7	DESIGN FOR FIRE RESISTANCE	82
7.1	General	82
7.2	Mechanical properties at elevated temperatures	82
7.3	Thermal properties at elevated temperatures	85
7.4	Determination of structural fire resistance	86
8	FATIGUE	94
9	TESTING	95
9.1	General	95
9.2	Stress-strain curve determination	95
9.3	Tests on members	95
10	FABRICATION ASPECTS	97
10.1	Introduction	97
10.2	Storage and handling	98
10.3	Shaping operations	98
10.4	Welding	100
10.5	Galling and seizure	104
10.6	Finishing	105
APPENDIX A	Correlation between stainless steel designations	107
APPENDIX B	Lateral-torsional buckling	109
APPENDIX C	Material data for deflection calculations	113
<b>PART II – DESIGN EXAMPLES</b>		
Design example 1		117
Design example 2		119
Design example 3		123
Design example 4		131
Design example 5		135
Design example 6		143
Design example 7		149
Design example 8		155
Design example 9		161
Design example 10		169
Design example 11		177
Design example 12		183
Design example 13		191



# PART 1 - RECOMMENDATIONS

## 1 INTRODUCTION

### 1.1 Scope

The recommendations given in this part of the Design Manual apply to the grades of stainless steel that are typically used in structural applications. The recommendations are intended primarily for the design of elements and secondary structural components of buildings, offshore installations and similar structures. They should not be applied to special structures such as those in nuclear installations or pressure vessels for which specific standards for stainless steel application already exist.

The recommendations concern aspects of material behaviour, the design of cold formed and welded members, and their connections. They are applicable to the austenitic and duplex grades of stainless steel that are typically used in structural or architectural applications. The recommendations have been formulated using limit state philosophy.

### 1.2 Symbols

In general, the symbols used in this Design Manual are the same as used in EN 1993-1-1: Eurocode 3, *Design of steel structures: General rules and rules for buildings*. Extensive use is made of subscripts, e.g.  $N_{b,z,Rd}$  is the design resistance (subscript Rd) of a column under axial load ( $N$ ) to buckling (subscript b) about the minor axis (subscript z).

Dimensions and axes of sections are illustrated in Figure 1.1. Note that contrary to normal practice in many countries, the major axis of a section is normally y-y and the minor axis z-z, see Section 1.3.

#### ***Latin upper case letters***

<i>A</i>	Accidental action; Area
<i>C</i>	Fixed value; Factor
<i>E</i>	Modulus of elasticity; Effect of actions
<i>F</i>	Action; Force
<i>G</i>	Permanent action; Shear modulus
<i>I</i>	Second moment of area
<i>L</i>	Length; Span; System length
<i>M</i>	Bending moment
<i>N</i>	Axial force
<i>Q</i>	Variable action
<i>R</i>	Resistance
<i>V</i>	Shear force
<i>W</i>	Section modulus

**Greek upper case letters**

$\Delta$  Difference in ..... (precedes main symbol)

**Latin lower case letters**

$a$  Distance between stiffeners; Throat thickness of a weld  
 $b$  Width; Breadth  
 $c$  Distance; Outstand  
 $d$  Diameter; Depth  
 $e$  Eccentricity; Shift of neutral axis; Edge distance; End distance  
 $f$  Strength (of a material)  
 $g$  Gap  
 $h$  Height  
 $i$  Radius of gyration; Integer  
 $k$  Coefficient; Factor  
 $l$  Buckling length  
 $m$  Constant  
 $n$  Number of ...  
 $p$  Pitch; Spacing  
 $q$  Distributed force  
 $r$  Radius; Root radius  
 $s$  Staggered pitch  
 $t$  Thickness  
 $uu$  Major axis  
 $vv$  Minor axis  
 $w$  Curling deformation  
 $xx, yy, zz$  Rectangular axes

**Greek lower case letters**

$\alpha$  (alpha) Ratio; Factor  
 $\beta$  (beta) Ratio; Factor  
 $\gamma$  (gamma) Partial factor  
 $\epsilon$  (epsilon) Strain; Coefficient =  $\left( \frac{235 E}{210000 f_y} \right)^{0,5}$   
 $\lambda$  (lambda) Slenderness ratio (a bar above indicates non dimensional)  
 $\rho$  (rho) Reduction factor  
 $\sigma$  (sigma) Normal stress  
 $\tau$  (tau) Shear stress  
 $\varphi$  (phi) Ratio  
 $\chi$  (chi) Reduction factor (for buckling)  
 $\psi$  (psi) Stress ratio; Reduction factor

**Subscripts**

$a$  Average  
 $b$  Bearing; Buckling; Bolt  
 $c$  Cross section  
 $cr$  Critical

d	Design
E	Euler; Internal force; Internal moment
eff	Effective
e	Effective (with further subscript)
el	Elastic
f	Flange
g	Gross
$i,j,k$	Indices (replace by numeral)
k	Characteristic
LT	Lateral-torsional
M	(Allowing for) bending moment
N	(Allowing for) axial force
net	Net
o	Initial
pl	Plastic
R	Resistance
r	Reduced value
S	Secant
s	Tensile stress (area); Stiffener
t	Tension; Tensile; Torsion
u	Major axis of cross-section; Ultimate
V	(Allowing for) shear force
v	Shear; Minor axis of cross-section
w	Web; Weld; Warping
x	Axis along member
y	Yield (proof value); Axis of cross-section (major axis except for unsymmetric sections)
z	Axis of cross-section (minor axis except for unsymmetric sections)
$\sigma$	Normal stress
$\tau$	Shear stress.

### 1.3 Conventions for member axes

In general, the convention for member axes is:

xx	along the length of the member.
yy	cross-section axis perpendicular to web, or the larger leg in the case of angle sections.
zz	cross-section axis parallel to web, or the larger leg in the case of angle sections.

The yy axis will normally be the major axis of the section and the zz axis will normally be the minor axis. For angle sections, the major and minor axes (uu and vv) are inclined to the yy and zz axes, see Figure 1.1.

The convention used for subscripts which indicate axes for moments is:  
*“Use the axis about which the moment acts”.*

For example, for an I-section a bending moment acting in the plane of the web is denoted  $M_y$  because it acts about the cross-section axis perpendicular to the web.

## 1.4 Units

For calculations, the following units are recommended:

- forces and loads            kN, kN/m, kN/m<sup>2</sup>
- unit mass                    kg/m<sup>3</sup>
- unit weight                 kN/m<sup>3</sup>
- stresses and strengths      N/mm<sup>2</sup> (= MN/m<sup>2</sup> or MPa)
- bending moments            kNm.

Note that, in accordance with European practice, a “,” symbol is used to separate the integer part from the decimal part in a number.

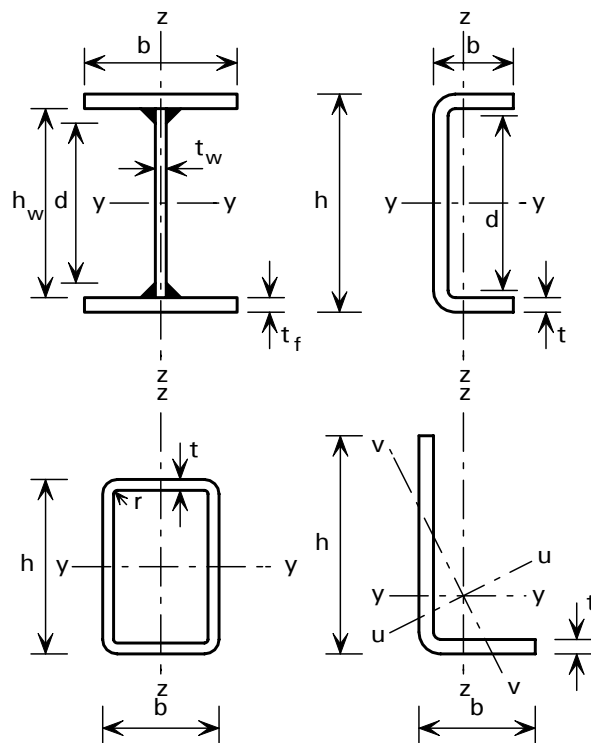


Figure 1.1 *Dimensions and axes of sections*

## **2 BASIS OF DESIGN**

### **2.1 General requirements**

A structure should be designed and fabricated so that it can:

- remain fit for use during its intended life
- sustain the loads which may occur during construction, installation and usage
- localise damage due to accidental overloads
- have adequate durability in relation to maintenance costs.

The above requirements can be satisfied by using suitable materials, by appropriate design and detailing and by specifying quality control procedures for construction and maintenance.

Structures should be designed by considering all relevant limit states.

### **2.2 Limit state design**

Limit states are limiting conditions which, when exceeded, make the structure unable to meet design performance criteria. Three classes of limit states are recognised: ultimate limit states, serviceability limit states and durability limit states. Ultimate limit states are those which, if exceeded, can lead to collapse of part or the whole of the structure, endangering the safety of people. Serviceability limit states correspond to states beyond which specified service criteria are no longer met. Durability limit states can be regarded as subsets of the ultimate and serviceability limit states depending on whether, for example, the corrosion affects the strength of the structure or its aesthetic appearance. Examples of these limit states are given below:

#### Ultimate Limit State

- Strength (including general yielding, rupture, buckling and transformation into a mechanism)
- Stability against over-turning and sway
- Fracture due to fatigue

#### Serviceability Limit State

- Deflection
- Vibration (e.g. wind induced)
- Repairable damage due to fatigue
- Creep

#### Durability Limit State

- Corrosion
- Metallurgical stability

### **Ultimate limit states**

For ultimate limit states, relationships of the following form have to be satisfied:

$$E_d \leq R_d \quad (2.1)$$

where:

$E_d$  is the design value of the effect of actions such as an internal moment or vector in the member or element under consideration due to the factored applied loading (see Section 2.3) acting on the structure, and

$R_d$  is the corresponding design resistance, as given in the appropriate clause in these recommendations.

The design resistance,  $R_d$ , is generally given as  $R_k/\gamma_M$  where  $R_k$  is a characteristic resistance and  $\gamma_M$  is a partial factor. The partial factor  $\gamma_M$  takes on various values. Table 2.1 gives the  $\gamma_M$  values to be used with this Design Manual which are taken from EN 1993-1-4 and EN 1993-1-8. Reference should also be made to the National Annex (NA) to EN 1993-1-4 and other relevant parts of EN 1993 for the country for which the structure is being designed because modified values for  $\gamma_M$  may be given that should be used instead of the values given in Table 2.1. (If a NA is not available, then  $\gamma_M$  factors should be agreed with the relevant national regulator.)

As an alternative to analysis, the design resistance may be assessed by testing of materials, components and structures (for guidance see Section 9).

**Table 2.1 Recommended values of  $\gamma_M$**

<b>For resistance of:</b>	<b>Symbol</b>	<b>Value (EN 1993-1-4)</b>
Cross-sections to excessive yielding including buckling	$\gamma_{M0}$	1,10
Members to instability assessed by member checks	$\gamma_{M1}$	1,10
Cross-sections in tension to fracture	$\gamma_{M2}$	1,25
Bolts, welds, pins and plates in bearing	$\gamma_{M2}$	1,25

<b>For resistance of:</b>	<b>Symbol</b>	<b>Value (EN 1993-1-8)</b>
Joints in hollow section lattice girder	$\gamma_{M5}$	1,00
Pins at the serviceability limit state	$\gamma_{M6,ser}$	1,00

### **Serviceability limit states**

The corresponding relationship for serviceability limit states is:

$$E_d \leq C_d \quad (2.2)$$

where:

$E_d$  is the design value of the effects of actions specified in the serviceability criterion e.g. member deflection response to forces and

moments in the member due to the unfactored applied loading ( $F_k$ , see Section 2.3.4), and

$C_d$  is the limiting design value of the relevant serviceability criterion.

### **Durability limit states**

These states require consideration of the corrosion phenomena addressed in Section 3.7.

## **2.3 Loading**

### **2.3.1 General**

In the Eurocodes, loading is expressed terms of ‘actions’. An ‘action’ is defined as:

- A set of forces (loads) applied to the structure (direct action)
- A set of imposed deformations or accelerations caused by, for example temperature changes, moisture variation, uneven settlement or earthquakes (indirect action).

Characteristic values ( $F_k$ ) of individual actions are specified:

- in EN 1991 *Actions on structures* (taking into account possible additions and/or changes in the relevant National Annex) or other relevant loading code, or
- by the client, or the designer in consultation with the client, provided that the minimum provisions specified in the relevant loading codes or by a competent authority are observed.

The design values of individual actions ( $F_d$ ) are given by multiplying characteristic actions by partial factors for actions ( $\gamma_F$ ).

The design case is established by considering all realistic combinations of actions and identifying the critical case.

### **2.3.2 Ultimate limit state - Onshore factored loads**

The following types of action are recognised:

- “Permanent” actions ( $G$ ) - e.g. self-weight of structures, fittings, ancillaries and fixed equipment.
- “Variable” actions ( $Q$ ) - e.g. imposed loads, wind loads, snow loads, and thermal loads.
- “Accidental” actions ( $A$ ) - e.g. explosions, fire and vehicle impact.

EN 1990 *Basis of Structural Design* gives combinations of actions for use in design of buildings and recommended values for partial factors for actions ( $\gamma_F$ ). Reference should also be made to the National Annex to EN 1990 for the country for which the structure is being designed because it may give modified values for  $\gamma_F$  that should be used instead of the recommended values. The NA also gives recommended values for the combination factors ( $\psi$  factors) and the unfavourable permanent actions ( $\xi$  factors). (If a NA is not available, then  $\gamma_F$ ,  $\psi$  and  $\xi$  factors should be agreed with the relevant national regulator.)

Reference should be made to the National Annex of EN 1991 regarding numerical values for loads.

As given in EN 1990, for normal usage, i.e. in situations not involving accidents, the combination of actions may be expressed as:

$$\sum_{j \geq 1} \gamma_{G,j} G_{k,j} + \gamma_{Q,1} Q_{k,1} + \sum_{i > 1} \gamma_{Q,i} \psi_{0,i} Q_{k,i} \quad (2.3)$$

or alternatively, the less favourable of the following expressions

$$\sum_{j \geq 1} \gamma_{G,j} G_{k,j} + \gamma_{Q,1} \psi_{0,1} Q_{k,1} + \sum_{i > 1} \gamma_{Q,i} \psi_{0,i} Q_{k,i} \quad (2.4a)$$

$$\sum_{j \geq 1} \xi_j \gamma_{G,j} G_{k,j} + \gamma_{Q,1} Q_{k,1} + \sum_{i > 1} \gamma_{Q,i} \psi_{0,i} Q_{k,i} \quad (2.4b)$$

where:

- $G_{k,j}$  is the characteristic value of the permanent action
- $Q_{k,1}$  is the characteristic value of leading variable action 1 (i.e. the most unfavourable variable action)
- $Q_{k,i}$  are the characteristic values of the accompanying variable actions  $i$
- $j$  is the index for permanent action
- $i$  is the index for variable action
- $\gamma_{G,j}$  is the partial factor for the permanent action  $G_{k,j}$
- $\gamma_{Q,1}$  is the partial factor for the leading variable action 1
- $\xi_j$  is a reduction factor for unfavourable permanent actions  $G$
- $\psi_{0,i}$  is a reduction factor for combination value of a variable action  $Q$ .

However, reference again should be made to the NA for the particular country for which the structure is being designed.

The following recommended values are given in EN 1990:

$$\begin{aligned} \gamma_{G,j} &= 1,35 \quad (\text{for unfavourable effects}) \\ \gamma_{Q,1} &= 1,5 \quad \gamma_{Q,i} = 1,5 \\ \xi &= 0,85 \end{aligned}$$

The value of  $\psi_0$  depends on the type of loading (see EN 1990).

Equations 2.4a and 2.4b were introduced because Equation 2.3 was unduly pessimistic for heavyweight structures. For steel structures, Equations 2.4a and 2.4b generally result in lighter loads than Equation 2.3.

### 2.3.3 Ultimate limit state - Offshore factored loads

Reference may be made to API RP2A - LRFD *Recommended Practice for Planning, Designing and Constructing Fixed Offshore Platforms - Load and Resistance Factor Design*, First Edition, 1993.

The following factored load combinations from API RP2A for the in-place condition are suggested for use in this Design Manual in conjunction with the



loads specified in API RP2A for the design of topside stainless steel components. Note that the notation is as used in API RP2A.

**Operating conditions:**

$$1,3D_1 + 1,3D_2 + 1,5L_1 + 1,5L_2 + 1,2(W_o + 1,25D_n) \quad (2.5)$$

**Extreme storm conditions:**

$$1,1D_1 + 1,1D_2 + 1,1L_1 + 1,35(W_e + 1,25D_n) \quad (2.6)$$

When internal forces due to gravity loads oppose the internal forces due to wind, wave and current loads, the gravity loads should be reduced such that:

$$0,9D_1 + 0,9D_2 + 0,8L_1 + 1,35(W_e + 1,25D_n) \quad (2.7)$$

where:

- $D_1$  is the dead load, including self-weight of structures, fittings, ancillaries and permanent equipment
- $D_2$  is the dead load, including weight of equipment and other objects which may change from one mode of operation to another
- $L_1$  is Live load 1 (includes weight of consumable supplies in pipes and tanks)
- $L_2$  is Live load 2 (short duration forces arising from operations such as lifting of drill string, lifting by cranes, machine operations, vessel mooring and helicopter loadings)
- $W_o$  is the operator defined operating wind, wave and current load or effects
- $W_e$  are the extreme wind, wave and current load or effects (100 year return period)
- $D_n$  are the inertial forces.

### 2.3.4 Serviceability limit state loads

Serviceability limit states should be checked for the following combinations:

- characteristic
- frequent
- quasi-permanent load combinations.

EN 1990 gives combinations of actions for use in design of buildings. (Reference should also be made to the NA for the particular country for which the structure is being designed.) EN 1990 also requires that the acceptable deflection should be agreed with the client.

For the characteristic combination, normally used for irreversible limit states, the following load combination should be used:

$$\sum_{j \geq 1} G_{k,j} + Q_{k,1} + \sum_{i > 1} \psi_{0,i} Q_{k,i} \quad (2.8)$$

where all terms are defined in Section 2.3.2.

Note that EN 1990 gives the appropriate combinations of actions to use in the following situations:

- for calculating deflections under normal combinations of actions (Clause A.1.4.3(1))
- when long term deformations due to shrinkage, relaxation or creep need to be considered (Clause A.1.4.3(6))
- if the appearance of the structure or the comfort of the user or functioning of machinery are being considered (Clauses A.1.4.3(4) and (5)).

## 3 MATERIALS: PROPERTIES, SELECTION AND DURABILITY

### 3.1 Material grades

#### 3.1.1 Introduction

There are many different types of stainless steel. Not all of these are suitable for structural applications, particularly where welding is contemplated. There are five basic groups of stainless steel, classified according to their metallurgical structure: these are the austenitic, ferritic, martensitic, duplex and precipitation-hardening groups. The austenitic stainless steels and the duplex stainless steels are generally the more useful groups for structural applications.

Austenitic stainless steels provide a good combination of corrosion resistance, forming and fabrication properties. Duplex stainless steels have high strength and wear resistance with very good resistance to stress corrosion cracking.

The most commonly used grades, typically referred to as the standard austenitic grades, are 1.4301 (widely known as 304) and 1.4401 (widely known as 316). They contain about 17-18% chromium and 8-11% nickel. Grade 1.4301 is suitable for rural, urban and light industrial sites whilst grade 1.4401 is a more highly alloyed grade and will perform well in marine and industrial sites.

The low carbon versions of these grades are 1.4307 (304L) and 1.4404 (316L). Grades 1.4301 and 1.4401 were formerly made with significantly higher carbon levels with implications for corrosion behaviour<sup>1</sup>. Either the 'L' grade, or a stabilised steel such as 1.4541 and 1.4571 would have been used where there was concern about corrosion performance in the as-welded condition.

Grade 1.4318 is a low carbon, high nitrogen stainless steel which work hardens very rapidly when cold worked. It has a long track record of satisfactory performance in the railcar industry and is equally suitable for automotive, aircraft and architectural applications. Grade 1.4318 has similar corrosion resistance to 1.4301 and is most suitable for applications requiring higher strength than 1.4301 where large volumes are required. It is procured directly from the mill; specifiers interested in using 1.4318 should check availability directly with the mill. Its price is likely to be slightly higher than 1.4301, depending on the amount required.

An increasing use of stainless steels for load bearing applications has led to a demand for 'lean' duplex grades in which the mechanical and corrosion properties of duplex grades are combined with a leanly alloyed chemical composition. In the forthcoming Parts 4 and 5 of EN 10088 (see Section 3.1.2), the newly developed duplex grade 1.4162 is included. Grade 1.4162 is suitable for many applications in the construction sector with a proof strength in

---

<sup>1</sup> Carbon present in the steel reacts with chromium and precipitates chromium carbides on grain boundaries under certain thermal cycles, e.g. in the weld heat affected zones (HAZ). The local loss of chromium from the boundary region into the carbide particles allows preferential intercrystalline corrosion attack and the steel is said to be *sensitized*, or to suffer from *weld decay* (see Section 3.7.2).

the range of 450 – 530 N/mm<sup>2</sup>, a corrosion resistance between the austenitic grades 1.4301 and 1.4404 and a lean chemical composition.

Only the rolled versions, as opposed to the cast versions, are considered. Guidance on grade selection for particular applications is given in Section 3.6.

### 3.1.2 Relevant standards

#### *Flat and long products*

The relevant standard is EN 10088, *Stainless steels*. It comprises three parts:

- Part 1, *Lists of stainless steels*, gives the chemical compositions and reference data on some physical properties such as modulus of elasticity, *E*.
- Part 2, *Technical delivery conditions for sheet, plate and strip of corrosion resisting steels for general purposes*, gives the technical properties and chemical compositions for the materials used in forming structural sections.
- Part 3, *Technical delivery conditions for semi-finished products, bars, rods, wire, sections and bright products of corrosion resisting steels for general purposes*, gives the technical properties and chemical compositions for the materials used in long products.

Parts 4 (flat products) and 5 (long products) of EN 10088 are now in preparation to cover material for construction purposes. They are likely to be published in 2007.

The designation systems adopted in EN 10088 are the European steel number and a steel name.

For example, grade 304L has a steel number 1.4307, where:

<b>1.</b>	<b>43</b>	<b>07</b>
Denotes steel	Denotes one group of stainless steels	Individual grade identification

The steel name system provides some understanding of the steel composition. The name of the steel number 1.4307 is X2CrNi18-9, where:

<b>X</b>	<b>2</b>	<b>CrNi</b>	<b>18-9</b>
Denotes high alloy steel	100 x % of carbon	Chemical symbols of main alloying elements	% of main alloying elements

Each stainless steel name has a unique corresponding steel number. Appendix A gives a table showing the designations for equivalent grades of stainless steel in various national and European standards.

Table 3.1 gives minimum specified mechanical properties of common stainless steels to EN 10088-2. The chemical compositions of these grades are given in Table 3.2.

Both austenitic and duplex stainless steels can be assumed to be adequately tough and not susceptible to brittle fracture for service temperatures down to  $-40^{\circ}\text{C}$ .

Design values of the mechanical properties are addressed in Section 3.2.4.

**Table 3.1** Specified mechanical properties of common stainless steels to EN 10088-2

	Grade	Product form <sup>(1)</sup>	Max thickness (mm)	Minimum 0.2% proof strength <sup>(2)</sup> (N/mm <sup>2</sup> )	Ultimate tensile strength (N/mm <sup>2</sup> )	Elongation after fracture (%)
Basic chromium-nickel austenitic steels	1.4301	C	8	230	540 – 750	45 <sup>(3)</sup>
		H	13,5	210	520 – 720	45 <sup>(3)</sup>
		P	75	210	520 – 720	45
	1.4307	C	8	220	520 – 700	45
		H	13,5	200	520 – 700	45
		P	75	200	500 – 700	45
Molybdenum-chromium-nickel austenitic steels	1.4401	C	8	240	530 – 680	40
		H	13,5	220	530 – 680	40
		P	75	220	520 – 670	45
	1.4404	C	8	240	530 – 680	40
		H	13,5	220	530 – 680	40
		P	75	220	520 – 670	45
Stabilised austenitic steels	1.4541	C	8	220	520 – 720	40
		H	13,5	200	520 – 720	40
		P	75	200	500 – 700	40
	1.4571	C	8	240	540 – 690	40
		H	13,5	220	540 – 690	40
		P	75	220	520 – 670	40
Low carbon, high nitrogen austenitic steel	1.4318	C	8	350	650 – 850	35
		H	13,5	330	650 – 850	35
		P	75	330	630 – 830	45
Duplex steels	1.4362	C	8	450	650 – 850	20
		H	13,5	400	650 – 850	20
		P	75	400	630 – 800	25
	1.4462	C	8	500	700 – 950	20
		H	13,5	460	700 – 950	25
		P	75	460	640 – 840	25

Notes:

(1) C = cold rolled strip, H = hot rolled strip, P = hot rolled plate

(2) Transverse properties

(3) For stretcher levelled material, the minimum value is 5% lower

**Table 3.2** *Chemical composition to EN 10088-2*

	Grade	Content of alloying element (maximum or range permitted) weight %				
		C	Cr	Ni	Mo	Others
Austenitic steels	1.4301	0,07	17,5 – 19,5	8,0 – 10,5		
	1.4307	0,03	17,5 – 19,5	8,0 – 10,5		
	1.4401	0,07	16,5 – 18,5	10,0 – 13,0	2,0 – 2,5	
	1.4404	0,03	16,5 – 18,5	10,0 – 13,0	2,0 – 2,5	
	1.4541	0,08	17,0 – 19,0	9,0 – 12,0		Ti: 5xC – 0,7 <sup>(1)</sup>
	1.4571	0,08	16,5 – 18,5	10,5 – 13,5	2,0 – 2,5	Ti: 5xC – 0,7 <sup>(1)</sup>
	1.4318	0,03	16,5 – 18,5	6,0 - 8,0		N: 0,1 – 0,2
Duplex steels	1.4362	0,03	22,0 – 24,0	3,5 – 5,5	0,1 – 0,6	N: 0,05 – 0,2
	1.4462	0,03	21,0 – 23,0	4,5 – 6,5	2,5 – 3,5	N: 0,1 – 0,22

Note:

(1) Titanium is added to stabilise carbon and improve corrosion performance in the heat affected zones of welds. However, except for very heavy section construction, the use of titanium stabilised austenitic steels has been superseded largely by the ready availability of the low carbon grades, 1.4307 and 1.4404.

### **Bolts**

Stainless steel bolts are covered by EN ISO 3506, *Corrosion-resistant stainless steel fasteners*. The specification gives chemical compositions and mechanical properties for fasteners in the austenitic, martensitic and ferritic groups. Alternative materials not specifically covered in the specification are permitted if they meet the physical and mechanical property requirements and have equivalent corrosion resistance.

In EN ISO 3506, bolt and nut materials are classified by a letter: “A” for austenitic, “F” for ferritic and “C” for martensitic. It is recommended that austenitic bolts are used, for which the properties are as given in Tables 3.3 and 3.4 (taken from EN ISO 3506). The letter is followed by a number (1, 2, 3 4 or 5) which reflects the corrosion resistance; 1 representing the least durable and 5 the most durable.

Steel grade A1 is specially designed for machining. Due to high sulfur content, the steels within this grade have lower resistance to corrosion than corresponding steels with normal sulfur content. Care should be exercised if Grade A1 bolts are being considered, see Section 3.6.1.

Steels of grade A2 have equivalent corrosion resistance to grade 1.4301. Steels of grade A3 are stabilised stainless steels with equivalent corrosion resistance to grade 1.4541. (A stabilised steel is one which contains an addition of a strong carbide-forming agent such as titanium, which reacts preferentially with carbon and prevents formation of chromium carbides.)

Steels of grade A4 contain molybdenum and have equivalent corrosion resistance to grade 1.4401. Steels of grade A5 are stabilised molybdenum-bearing stainless steels with properties of grade 1.4571 steel.

Austenitic bolts can be obtained in three ultimate strength levels (known as property classes), see Table 3.3. Note that values must be agreed for bolts larger than M39 for property class 50 and M24 for property classes 70 and 80 as the values depend on the alloy and manufacturing method.

Bolts manufactured to property class 50 will be non-magnetic, but those to property classes 70 and 80 may demonstrate some magnetic properties.

The condition of the alloy in property class 50 bolts is soft, resulting in the highest corrosion resistance. Property classes 70 and 80 are cold worked and this can affect corrosion resistance slightly. Property class 50 bolts having machined threads may be more prone to thread galling, see Section 10.5.

Consideration should be given to matching the strength and corrosion resistance of the bolts and parent material.

EN 14399 gives rules for the CE marking of bolts.

**Table 3.3** *Minimum specified mechanical properties of austenitic grade bolts and nuts to EN ISO 3506*

Grade <sup>(1)</sup>	Property class	Thread diameter range	Bolts		Nuts
			Ultimate tensile strength <sup>(2)</sup> (N/mm <sup>2</sup> )	Stress at 0,2% permanent strain (N/mm <sup>2</sup> )	Proof load stress (N/mm <sup>2</sup> )
A1, A2, A3, A4 and A5	50	≤ M39	500	210	500
	70	≤ M24 <sup>(3)</sup>	700	450	700
	80	≤ M24 <sup>(3)</sup>	800	600	800

Notes:

- (1) In addition to the various steel types covered in EN ISO 3506 under property class 50, 70 and 80, other steel types to EN 10088-3 may also be used.
- (2) The tensile stress is calculated on the stress area.
- (3) For fasteners with nominal thread diameters  $d > 24$  mm, the mechanical properties shall be agreed upon between user and manufacturer and marked with grade and property class according to this table.

**Table 3.4** Chemical composition of bolts to EN ISO 3506

Grade	Chemical composition (percentage weight) <sup>(1)</sup>								
	C	Cr	Ni	Mo	Si	Mn	P	S	Others
A1	0,12	16,0 – 18,0	5,0 – 10,0	0,7	1,0	6,5	0,20	0,15 – 0,35	
A2	0,1	15,0 – 20,0	8,0 – 19,0	<sup>(2)</sup>	1,0	2,0	0,05	0,03	
A3	0,08	17,0 – 19,0	9,0 – 12,0	<sup>(2)</sup>	1,0	2,0	0,045	0,03	Either Ti: ≥ 5xC – 0,8 Or Nb/Ta: ≥ 10xC – 1,0
A4	0,08	16,0 – 18,5	10,0 – 15,0	2,0 – 3,0	1,0	2,0	0,045	0,03	
A5	0,08	16,0 – 18,5	10,5 – 14,0	2,0 – 3,0	1,0	2,0	0,045	0,03	Either Ti: ≥ 5xC – 0,8 Or Nb/Ta: ≥ 10xC – 1,0

Note:  
(1) Values are maxima unless indicated otherwise  
(2) Molybdenum may be present at the discretion of the manufacturer

## 3.2 Mechanical behaviour and design values of properties

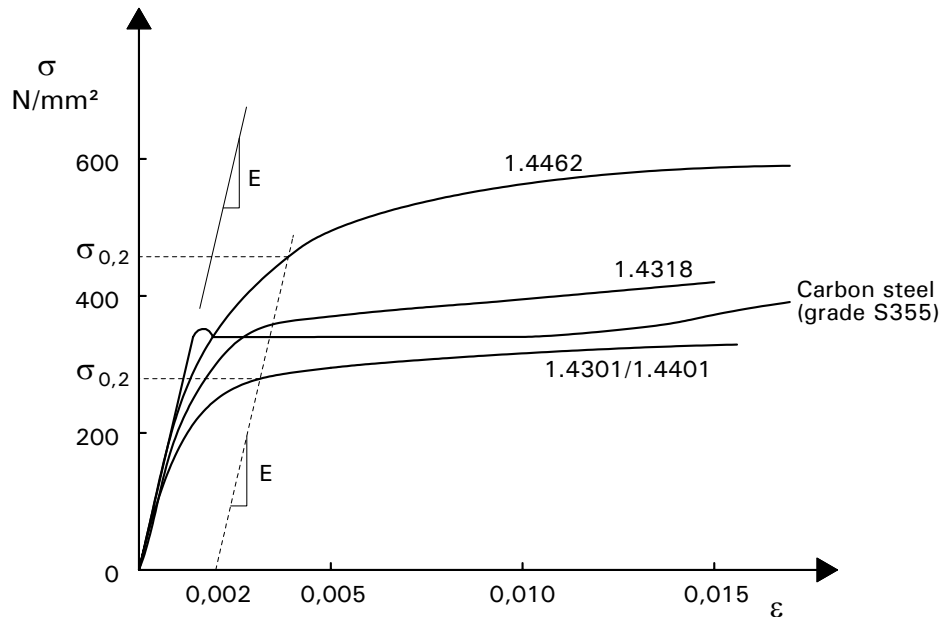
### 3.2.1 Basic stress-strain behaviour

The stress-strain behaviour of stainless steels differs from that of carbon steels in a number of respects. The most important difference is in the shape of the stress-strain curve. Whereas carbon steel typically exhibits linear elastic behaviour up to the yield stress and a plateau before strain hardening is encountered, stainless steel has a more rounded response with no well-defined yield stress (see Figure 3.1). Therefore, stainless steel “yield” strengths are generally quoted in terms of a proof strength defined for a particular offset permanent strain (conventionally the 0,2% strain), as indicated in the Figure 3.1.

Note that Figure 3.1 shows typical experimental stress-strain curves. The curves shown are representative of the range of material likely to be supplied and should not be used in design.

Stainless steels can absorb considerable impact without fracturing due to their excellent ductility (especially the austenitic grades) and their strain hardening characteristics.





( $\sigma_{0,2}$  is the 0,2% proof strength)

**Figure 3.1** Typical stress-strain curves for stainless steel and carbon steel in the annealed condition (for longitudinal tension)

### 3.2.2 Factors affecting stress-strain behaviour

There are factors that can change the form of the basic stress-strain curve for any given grade of stainless steel. These factors are to some extent interdependent and include:

#### **Cold working**

Strength levels of austenitic and duplex grades are enhanced by cold working (such as imparted during cold forming operations including roller levelling/flattening and also during fabrication). Associated with this enhancement is a reduction in ductility but this normally is of slight consequence due to the initial high values of ductility, especially for the austenitic stainless steels.

Table 3.5 gives the cold worked levels specified in EN 1993-1-4 which are taken from the European material standard for stainless steel, EN 10088. Cold worked steels may be specified either in terms of minimum 0,2% proof strength or ultimate tensile strength or hardness, but only one parameter can be specified.

As stainless steel is cold worked, it tends to exhibit non-symmetry of tensile and compressive behaviour and anisotropy (different stress-strain characteristics parallel and transverse to the rolling directions). The degree of asymmetry and anisotropy depends on the grade, level of cold working and manufacturing route. Figure 3.2 shows stress-strain curves for grade 1.4318 cold worked to C850; the compression strength in the longitudinal direction lies below the tensile strength in both the transverse and longitudinal direction (the values traditionally given in material standards such as EN 10088 and reported accordingly by suppliers). Care is therefore needed in the choice of design strength for cold worked material (see Section 3.2.4). Additional information about values related to other types or directions of loading should be sought from the supplier.

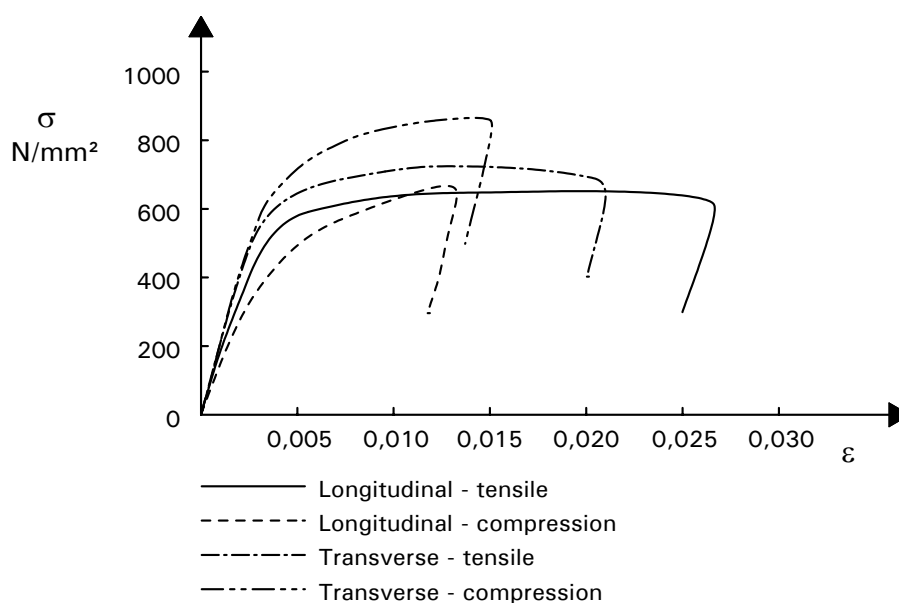
The price of cold worked stainless steel is slightly higher than the equivalent annealed material, depending on the grade, product form and level of cold working.

**Table 3.5** *Cold worked strength levels in EN 10088-2 (applicable to material of thickness  $\leq 6$  mm)*

Cold worked condition	Minimum 0,2% proof strength <sup>1) 2)</sup>	Minimum tensile strength <sup>1) 2)</sup>	Available steel grades in the cold worked condition
CP350	350	700 <sup>3)</sup>	1.4301, 1.4541, 1.4401, 1.4571
CP500	500	850 <sup>3)</sup>	1.4301, 1.4541, 1.4401, 1.4571, 1.4318
CP700	700	1000 <sup>3)</sup>	1.4318, 1.4301
C700	350 <sup>3)</sup>	700	1.4301, 1.4541, 1.4401, 1.4571
C850	500 <sup>3)</sup>	850	1.4301, 1.4541, 1.4401, 1.4571, 1.4318
C1000	700 <sup>3)</sup>	1000	1.4318, 1.4301

Note:

- (1) Intermediate 0,2% proof strength or tensile strength values may be agreed.
- (2) Maximum product thickness for each strength level decreases with strength. Maximum product thickness and remaining elongation are also dependent on the work hardening behaviour of the steel and the cold working conditions - more exact information may be requested from the manufacturer.
- (3) Not specified, indicative minimum values.



**Figure 3.2** *Typical stress-strain curves for grade 1.4318 cold worked to strength level C850*

During the fabrication of a section, a 0,2% proof strength enhancement by a factor of about 50% is typical in cold formed corners of cross sections. However, the effect is localised and the increase in member resistance is dependent on the location of the corners within the section; e.g. in a beam, little benefit would be obtained for corners close to the neutral axis. The strength enhancement easily compensates for any effect due to thinning of the material at cold worked corners. If advantage is to be made of localised increased strength arising from fabrication, this should be proved by testing (see Section 9).

Subsequent welding of the member will have a partial annealing effect with a consequential reduction in any enhanced strength properties arising from cold working - Section 6.4.4 gives guidance on the design of welded connections between members from cold worked material.

#### ***Strain-rate sensitivity***

Strain-rate sensitivity is more pronounced in stainless steels than in carbon steels. That is, a proportionally greater strength can be realised at fast strain rates for stainless steel than for carbon steel.

#### ***Heat treatment***

Annealing, or softening, reduces the strength enhancement and the anisotropy.

### **3.2.3 Typical values of properties**

It should be apparent from Sections 3.2.1 and 3.2.2 above that more factors are involved when considering the mechanical properties of stainless steels than for carbon steels. Their metallurgy is more complex and the manufacturing process has a higher impact on their final properties. For any given grade it is to be expected that there will be differences in properties for materials made by different manufacturers. However, the mechanical properties, being dependent on chemical composition and thermo-mechanical treatment, are therefore largely under the control of the manufacturers and it is possible to negotiate desired properties with individual manufacturers.

From a structural point of view, the margin by which the actual 0,2% proof stress exceeds the minimum specified value is significant. Typical mean proof stresses lie between 20 and 35% above the specified minima. The proportions of enhancement observed for proof stresses are not shared by ultimate tensile strength values, which typically are only about 10% above specified minima.

### **3.2.4 Design values of properties**

#### ***Flat products***

Three options may be considered: minimum specified values, verified material test data or mill certificate data.

- (i) Design using minimum specified values

#### ***Annealed material***

Take the characteristic yield strength,  $f_y$ , and the characteristic ultimate tensile strength,  $f_u$  as the minimum values specified in EN 10088-2 (given in Table 3.1).

#### ***Cold worked material***

Increased nominal values of  $f_y$  and  $f_u$  may be adopted for material delivered in the cold worked conditions specified in EN 10088.

For material delivered to a specified 0,2% proof strength (e.g. CP350), the minimum 0,2% proof strength in Table 3.5 may be taken as the characteristic strength. To take into account asymmetry of the cold worked material in those cases where compression in the longitudinal direction is a relevant stress condition (i.e. column behaviour or bending), the characteristic value should be taken as  $0.8 \times 0.2\%$  proof strength in

Table 3.5. A higher value may be used if supported by appropriate experimental data.

For material delivered to a specified tensile strength (e.g. C700), the minimum tensile strength in Table 3.5 may be taken as the characteristic strength; the minimum 0,2% proof strength should be obtained from the supplier.

*Note 1:* Rectangular hollow sections are available in material cold worked to intermediate strengths between CP350 and CP500 with the yield and ultimate tensile strength guaranteed by the producer (the yield strength being valid in tension and compression).

*Note 2:* The design rules in this Design Manual are applicable for material up to grade CP500 and C850. For higher cold worked strength levels, design should be by testing according to Section 9. An exception is members with Class 1, 2 and 3 cross-sections which are not subject to local or global instability, for which the cross-section resistance may be calculated according to Section 4.

(ii) Design using test data

This should only be considered as an option where tensile testing has been carried out on coupons cut from the plate or sheet from which the members are to be formed or fabricated. The designer should also be satisfied that the tests have been carried out to a recognised standard, e.g. EN 10002-1, and that the procedures adopted by the fabricator are such that the member will be actually made from the tested material and positioned correctly within the structure.

A value for the design strength can be derived from a statistical approach carried out in accordance with the recommendations in Annex D of EN 1990.

It is recommended that the characteristic ultimate tensile strength,  $f_u$ , should still be based on the specified minimum value given in EN 10088-2.

(iii) Design using mill certificate data

Measured values of the 0,2% proof stress are given on the mill (or release) certificate. A value for the design strength can be derived from a statistical approach carried out in accordance with the recommendations in Annex D of EN 1990.

It is recommended that the characteristic ultimate tensile strength,  $f_u$ , should still be based on the specified minimum value given in EN 10088-2.

A value of 200 000 N/mm<sup>2</sup> is given by EN 10088-1 for Young's modulus for all the standard austenitic and duplex grades typically used in structural applications. For estimating deflections, the secant modulus is more appropriate, see Section 5.4.6. For these grades, a value of 0,3 can be taken for Poisson's ratio and 76 900 N/mm<sup>2</sup> for the shear modulus,  $G$ .

### **Bolts**

For calculating the resistance of a bolt under tension or shear or combined tension and shear, take the basic strength  $f_{ub}$  as:

$$f_{ub} = \sigma_{ub}$$

where  $\sigma_{ub}$  is the specified minimum ultimate tensile strength given in Table 3.3 for the appropriate property class.

When it is necessary to consider the long term resistance of a bolt, reference should be made to EN 1990 for the appropriate combination of actions at the Ultimate Limit State.

### 3.3 Physical properties

Table 3.6 gives the room temperature physical properties in the annealed condition of the range of EN 10088 grades covered in this Design Manual. Physical properties may vary slightly with product form and size but such variations are usually not of critical importance to the application.

**Table 3.6** *Room temperature physical properties, annealed condition*

Grade	Density (kg/m <sup>3</sup> )	Thermal expansion 20 – 100°C (10 <sup>-6</sup> /°C)	Thermal conductivity (W/m°C)	Heat capacity (J/kg°C)
1.4301	7900	16	15	500
1.4307	7900	16	15	500
1.4401	8000	16	15	500
1.4404	8000	16	15	500
1.4541	7900	16	15	500
1.4571	8000	16,5	15	500
1.4318	7900	16	15	500
1.4362	7800	13	15	500
1.4462	7800	13	15	500

From a structural point of view, the most important physical property is the coefficient of linear expansion which, for the austenitic grades, differs considerably from that for carbon steel ( $12 \times 10^{-6}/^{\circ}\text{C}$ ). Where carbon and stainless steel are used together, the effects of differential thermal expansion should be considered in design.

Duplex and ferritic grades are magnetic. Where the non-magnetic properties of the austenitic grades are important to the application, care must be exercised in selecting appropriate welding consumables to minimise the ferrite content in the weldment. Heavy cold working, particularly of the lean alloyed austenitic steel, can also increase magnetic permeability; subsequent annealing would restore the non-magnetic properties. For non-magnetic applications, it is recommended that further advice be obtained from a steel producer.

### 3.4 Effects of temperature

Austenitic grades are used for cryogenic applications. At the other end of the temperature scale, austenitic and duplex grades retain a higher proportion of their strength above about 550°C than carbon steel. However, the design of structures subject to long term exposure at cryogenic temperatures or to long

term exposure at high temperatures is outside the scope of this Design Manual. Suffice it to say that other mechanical properties and types of corrosion than those considered in this Section 3 take on a greater significance. Other stainless steels than those selected here are in most cases better suited for high temperature applications and further advice should be sought.

Duplex steels should not be used for long periods at temperatures above about 300°C, due to the possibility of embrittlement.

Section 7 covers fire resistant design and gives mechanical and physical properties at high temperatures.

### **3.5 Life cycle costing**

There is increasing awareness that life cycle (or whole life) costs, not just initial costs, should be considered when selecting materials. Life cycle costs take account of:

- initial costs,
- operating costs,
- residual value.

Stainless steel is sometimes considered to be an expensive material. However, experience has shown that using a corrosion resistant material in order to avoid future maintenance, downtime and replacement costs can save costs which far outweigh higher initial material costs.

The initial cost of a structural stainless steel product is considerably higher than that of an equivalent carbon steel product, depending on the grade of stainless steel. However, savings will arise from the omission of surface coatings at regular (repeated) intervals in time.

The excellent corrosion resistance of stainless steel can offer many benefits including:

- reduced inspection frequency and costs,
- reduced maintenance costs,
- long service life.

Stainless steel has a high residual value (i.e. value at the end of a structure's life), though this is rarely a deciding factor for a structure with a long projected life (for instance over 50 years).

Life cycle costing uses the standard accountancy principle of discounted cash flow to reduce all those costs to present day values. The discount rate encompasses inflation, bank interest rates, taxes and, possibly, a risk factor. This allows a realistic comparison to be made of the options available and the potential long term benefits of using stainless steel to be assessed against other material selections.

## **3.6 Selection of materials**

### **3.6.1 Grades**

In the great majority of structural applications utilising stainless steel, it is the metal's corrosion resistance, which is being exploited, whether this be for reasons of aesthetics, minimal maintenance or long-term durability. Corrosion resistance must therefore be the primary factor in choosing a suitable grade.

Stainless steels derive their corrosion resistance from the presence of a passive surface film which, given adequate access to oxygen or suitable oxidising agents, tends to be self-healing when damaged. This oxide film is primarily a consequence of the chromium content of the steel, though the addition of nickel and other alloying elements can substantially enhance the protection offered by the film. In particular, a small percentage of molybdenum is used to improve the pitting resistance of the steel (see Section 3.7.2).

It is when the surface oxide film is damaged, possibly by electro-chemical attack or by mechanical damage, that corrosion might initiate.

Careful design should ensure trouble-free performance, but designers should be aware that even stainless steels may be subject to various forms of corrosion under certain circumstances. Notwithstanding the existence of these degradation effects, it is perfectly possible to employ stainless steels extremely effectively, provided that a few elementary principles are kept in mind. It is only when these materials are used without consideration for the principles behind their corrosion properties that problems might be encountered.

The selection of the correct grade of stainless steel must take into account the environment of the application, the fabrication route, surface finish and the maintenance of the structure. It might be noted that the maintenance requirement is minimal: merely washing down the stainless steel, even naturally by rain, will markedly assist in extending the service life.

The first step is to characterise the service environment, including reasonably anticipated deviations from the design conditions. In categorising atmospheric environments, special attention should be given to highly localised conditions such as proximity to chimneys venting corrosive fumes. Possible future developments or change of use should also be considered. The surface condition and the temperature of the steel, and the anticipated stress, could also be important parameters (see Section 3.7.2).

Candidate grades can then be chosen to give overall satisfactory corrosion resistance in the environment. The selection of a candidate steel should consider which possible forms of corrosion might be significant in the operating environment. To do this requires some appreciation of the nature of corrosion found in stainless steels. Section 3.7 outlines the broad principles underlying the corrosion of stainless steels, and indicates conditions where use of stainless steels should be free of undue risk and complication. It is also intended to illustrate general points of good practice, as well as the circumstances where stainless steels might have to be used with caution. In these latter conditions specialist advice should be sought, for in many cases the steels can still be successfully used.

Consideration should then be given to mechanical properties, ease of fabrication, availability of product forms, surface finish and costs.

Assessing the suitability of grades is best approached by referring to experience of stainless steels in similar applications and environments. Table 3.7 gives guidance for selecting suitable grades for atmospheric environments. National regulations should also be checked, since in some cases they may be more onerous. In the case of immersed stainless steel, see Section 3.7.3. When stainless steel comes into contact with chemicals, expert advice should always be sought.

Caution should be exercised when considering the use of *free-machining* stainless steels for fasteners. The addition of sulfur in the composition of these steels in the austenitic class renders them more liable to corrosion, especially in industrial and marine environments. In particular, this applies to fasteners in EN ISO 3506 grade A1 materials, see Table 3.3.

**Table 3.7** *Suggested grades for atmospheric applications*

Steel grade	Location											
	Rural			Urban			Industrial			Marine		
	L	M	H	L	M	H	L	M	H	L	M	H
Basic chromium-nickel austenitic steels (e.g. 1.4301, 1.4307, 1.4541, 1.4318)	✓	✓	✓	✓	✓	(✓)	(✓)	(✓)	X	✓	(✓)	X
Molybdenum-chromium-nickel austenitic steels (e.g. 1.4401, 1.4404, 1.4571) and duplex 1.4362	0	0	0	0	✓	✓	✓	✓	(✓)	✓	✓	(✓)
Duplex steel grade 1.4462	0	0	0	0	0	0	0	0	✓	0	0	✓

L Least corrosive conditions within that category, e.g. tempered by low humidity, low temperatures.  
M Fairly typical of that category.  
H Corrosion likely to be higher than typical for that category, e.g. increased by persistent high humidity, high ambient temperatures, and particularly aggressive air pollutants.  
O Potentially over-specified from a corrosion point of view.  
✓ Probably the best choice for corrosion resistance and cost.  
X Likely to suffer excessive corrosion.  
(✓) Worthy of consideration if precautions are taken (i.e. specifying a relatively smooth surface and if regular washing is carried out).

NOTE: National regulations may contain more onerous requirements.

### 3.6.2 Availability of product forms

#### *General types of product form*

Sheet, plate and bar products are all widely available in the grades of stainless steel considered in this Design Manual. Tubular products are available in austenitic grades and also the duplex grade 1.4462 (2205). Tubular products in the duplex grade 1.4362 (2304) are not widely available as this is a relatively new grade to the construction industry, although it has been used for some years for offshore blast walls.

There is a range of rolled sections (angles, channels, tees, rectangular hollow sections and I-sections) in standard austenitic grades such as 1.4301 and 1.4401 but none for duplex grades. Generally, sections may be produced by cold forming (rolling or bending), or fabricated by welding.



Material in the cold worked condition is available in various product forms including plate, sheet, coil, strip, bars and hollow sections:

- plate, sheet, coil, strip (in thicknesses typically  $\leq 6.0$  mm)
- round bar (diameters from 5 mm to 60 mm)
- square and rectangular hollow sections (cross-section dimensions up to 400 mm, thicknesses from 1.2 to 6 mm).

The grades of stainless steel which are commercially available in the cold worked condition are given in Table 3.5.

### ***Cold forming***

It is important that early discussion with potential fabricators takes place to ascertain cold forming limits as stainless steels require higher forming loads than carbon steels. The length of brake-pressed cold formed sections is necessarily limited by the size of machine or by power capability in the case of thicker or stronger materials. Duplex grades require approximately twice the forming loads used for the austenitic materials and consequently the possible range of duplex sections is more limited. Furthermore, because of the lower ductility in the duplex material, more generous bending radii should be used. Further information may be found in Section 10.3.2.

### ***Surface finish***

In certain applications, surface finish and appearance are important. Manufacturers offer a range of standard finishes, from mill finish through dull finishes to bright polish. They may also offer proprietary textured finishes. It should be noted that although the various finishes are standardised, variability in processing introduces differences in appearance between manufacturers and even from a single producer. Bright finishes are frequently used in architectural applications and it should be noted that bright finishes will exaggerate any out-of-flatness of the material, particularly on panel surfaces. Rigidised, embossed, textured, patterned or profiled sheets with a rigid supporting frame will alleviate this tendency.

### ***Bolts***

Bolts to EN ISO 3506 property class 70 are the most widely available. Certain size and length restrictions apply to bolts in property classes 70 and 80, see Table 3.3. It is possible to have “specials” made to order and indeed, this sometimes produces an economical solution.

Bolts can be produced by a number of techniques, e.g. machining, cold forming and forging. Machined threads should not be used in very aggressive environments (e.g. marine), due to potential problems with crevice corrosion. Rolled threads are also to be preferred because they are generally stronger than machined threads and provide greater resistance to thread galling.

## **3.7 Durability**

### **3.7.1 Introduction**

Stainless steels are generally very corrosion resistant and will perform satisfactorily in most environments. The limit of corrosion resistance of a given stainless steel depends on its constituent elements, which means that each grade has a slightly different response when exposed to a corrosive environment.

Care is therefore needed to select the most appropriate grade of stainless steel for a given application. Generally, the higher the level of corrosion resistance required, the greater the cost of the material. For example, grade 1.4401 steel costs more than grade 1.4301 because of the addition of molybdenum.

Material in the cold worked condition has a similar corrosion resistance to that in the annealed condition.

The most common reasons for a metal to fail to live up to expectations regarding corrosion resistance are:

- (a) incorrect assessment of the environment or exposure to unexpected conditions, e.g. unsuspected contamination by chloride ions
- (b) the way in which the stainless steel has been worked or treated may introduce a state not envisaged in the initial assessment.

Although stainless steel may be subject to discolouration and staining (often due to carbon steel contamination), it is extremely durable in buildings. In aggressive industrial and marine environments, tests have shown no indication of reduction in component capacity even where a small amount of weight loss occurred. However, the user may still regard unsightly rust staining on external surfaces as a failure. As well as careful material grade selection, good detailing and workmanship can significantly reduce the likelihood of staining and corrosion; practical guidance is given in Section 10. Experience indicates that any serious corrosion problem is most likely to show up in the first two or three years of service.

In certain aggressive environments, some grades of stainless steel will be susceptible to localised attack. Six mechanisms are described below although the last three are very rarely encountered in buildings onshore.

It should be emphasised that the presence of moisture (including that due to condensation) is necessary for corrosion to occur.

### **3.7.2 Types of corrosion and performance of steel grades**

#### ***Pitting corrosion***

As the name implies, pitting takes the form of localised pits. It occurs as a result of local breakdown of the passive layer, normally by chloride ions although the other halides and other anions can have a similar effect. In a developing pit, corrosion products may create a very corrosive solution, often leading to high corrosion rates. In most structural applications, the extent of pitting is likely to be superficial and the reduction in section of a component is negligible. However, corrosion products can stain architectural features. A less tolerant view of pitting should be adopted for services such as ducts, piping and containment structures.

Since the chloride ion is by far the most common cause of pitting, coastal and marine environments are rather aggressive. The probability of a certain medium causing pitting depends on, besides the chloride content, factors such as the temperature, acidity or alkalinity and the content of oxidising agents. The pitting resistance of a stainless steel is dependent on its chemical composition. Chromium, molybdenum and nitrogen all enhance the resistance to pitting.

An approximate measure of pitting resistance is given by the Pitting Index or Pitting Resistance Equivalent (PRE) defined as:

$PRE = \% \text{ wt Cr} + 3,3(\% \text{ wt Mo}) + 30(\% \text{ wt N})$  for austenitic grades

$PRE = \% \text{ wt Cr} + 3,3(\% \text{ wt Mo}) + 16(\% \text{ wt N})$  for duplex grades

The PRE of a stainless steel is a useful guide to its ranking with other stainless steels, but has no absolute significance.

Grade 1.4301 has the lowest PRE of the grades covered in this Design Manual and hence is the most unsuitable grade for architectural applications in marine environments except, perhaps, for internal structural components effectively shielded from sea spray and mist. Grade 1.4301 may also show unacceptable levels of pitting in severe industrial atmospheres and therefore grade 1.4401 or a duplex grade is to be preferred.

### ***Crevice corrosion***

Crevice corrosion occurs in the same environments as pitting corrosion. Corrosion initiates more easily in a crevice than on a free surface because the diffusion of oxidants necessary for maintaining the passive film is restricted. The severity of a crevice is very dependent on its geometry: the narrower and deeper the crevice, the more severe the corrosion conditions. It is only likely to be a problem in stagnant solutions where a build up of chlorides can occur.

Crevices may result from a metal to metal joint, a gasket, biofouling, deposits and surface damage such as deep scratches. Every effort should be made to eliminate crevices, but it is often not possible to eliminate them entirely.

As in pitting corrosion, the alloying elements chromium, molybdenum and nitrogen enhance the resistance to attack and thus the resistance to crevice corrosion increases from grade 1.4301 through 1.4401 to 1.4462.

### ***Bimetallic (galvanic) corrosion***

When two dissimilar metals are in electrical contact and are also bridged by an electrolyte (i.e. an electrically conducting liquid such as sea water or impure fresh water), a current flows from the anodic metal to the cathodic or nobler metal through the electrolyte. As a result the less noble metal corrodes.

This form of corrosion is particularly relevant when considering joining stainless steel and carbon or low alloy steels. It is important to select welding consumables that are at least as noble as the parent material. In corrosive environments where water may be present such as heavy industrial environments, marine atmospheres, and where immersion in brackish or sea water may occur, martensitic and ferritic bolts (see Section 3.1.2) should be avoided for joining austenitic stainless steels.

Bimetallic corrosion need not be a problem with stainless steels, though sometimes its prevention can require precautions which at first sight might seem surprising. The prevention of bimetallic corrosion, in principle, is to prevent current flow by:

- insulating dissimilar metals, i.e. breaking the metallic path (see Section 6.1.1).
- preventing electrolyte bridging, i.e. breaking the electrolytic path by paint or other coating. Where protection is sought by this means and it is impracticable to coat both metals, then it is preferable to coat the more

noble one (i.e. stainless steel in the case of a stainless/carbon steel connection).

The risk of a deep corrosion attack is greatest if the area of the more noble metal (i.e. stainless steel) is large compared with the area of the less noble metal (i.e. carbon steel). Special attention should be paid to the use of paints or other coatings on the carbon steel. If there are any small pores or pinholes in the coating, the small area of bare carbon steel will provide a very large cathode/anode area ratio, and severe pitting of the carbon steel may occur. This is, of course, likely to be most severe under immersed conditions. For this reason it is preferable to paint the stainless steel; any pores will lead to small area ratios.

Adverse area ratios are likely to occur with fasteners and at joints. Carbon steel bolts in stainless steel members should be avoided because the ratio of the area of the stainless steel to the carbon steel is large and the bolts will be subject to aggressive attack. Conversely, the rate of attack of a carbon steel member by a stainless steel bolt is much slower. It is usually helpful to draw on previous experience in similar sites because dissimilar metals can often be safely coupled under conditions of occasional condensation or dampness with no adverse effects, especially when the conductivity of the electrolyte is low.

The prediction of these effects is difficult because the corrosion rate is determined by a number of complex issues. The use of electrical potential tables ignores the presence of surface oxide films and the effects of area ratios and different solution (electrolyte) chemistry. Therefore, uninformed use of these tables may produce erroneous results. They should be used with care and only for initial assessment.

Stainless steels usually form the cathode in a bimetallic couple and therefore do not suffer corrosion. Contact between austenitic stainless steels and zinc or aluminium may result in some additional corrosion of the latter two metals. This is unlikely to be significant structurally, but the resulting white/grey powder may be deemed unsightly. The couple with copper should generally be avoided except under benign conditions.

The general behaviour of metals in bimetallic contact in rural, urban, industrial and coastal environments is fully documented in BS PD 6484 *Commentary on corrosion at bimetallic contacts and its alleviation*.

### ***Stress corrosion cracking***

The development of stress corrosion cracking (SCC) requires the simultaneous presence of tensile stresses and specific environmental factors unlikely to be encountered in normal building atmospheres. The stresses do not need to be very high in relation to the proof stress of the material and may be due to loading, residual effects from manufacturing processes such as welding or bending. Duplex stainless steels usually have superior resistance to stress corrosion cracking than the austenitic stainless steels covered in this Design Manual. Higher alloy austenitic stainless steels such as grades 1.4539, 1.4529, 1.4547 and 1.4565 (not covered in this Design Manual) have been developed for applications where SCC is a corrosion hazard.

Caution should be exercised when stainless steel members containing high residual stresses (e.g. due to cold working) are used in chloride rich environments (e.g. indoor swimming pools, marine, offshore). EN 1993-1-4

advises that for load-bearing members in atmospheres containing chlorides that cannot be cleaned regularly (e.g. in suspended ceilings above swimming pools), only grades 1.4529, 1.4547, 1.4565 should be used, unless the concentration of chloride ions in the pool water is (unusually)  $\leq 250$  mg/l, in which case grade 1.4539 is also suitable. Alternative grades which have been shown to have equivalent resistance to stress corrosion cracking in these atmospheres may also be used.

### ***General (uniform) corrosion***

Under normal conditions typically encountered in structural applications, stainless steels do not suffer from the general loss of section that is characteristic of rusting in non-alloyed irons and steels.

Stainless steel is resistant to many chemicals; indeed it is sometimes used for their containment. However, reference should be made to tables in manufacturers' literature, or the advice of a competent corrosion engineer should be sought, if the stainless steel is to come into contact with chemicals.

### ***Intergranular corrosion (sensitisation) and weld decay***

When austenitic stainless steels are subject to prolonged heating in the range 450°C to 850°C, the carbon in the steel diffuses to the grain boundaries and precipitates chromium carbide. This removes chromium from the solid solution and leaves a lower chromium content adjacent to the grain boundaries. Steel in this condition is termed *sensitized*. The grain boundaries become prone to preferential attack on subsequent exposure to a corrosive environment. This phenomenon is known as *weld decay* when it occurs in the heat affected zone of a weldment.

There are three ways to avoid intergranular corrosion:

- use steel having a low carbon content
- use steel stabilised with titanium or niobium, because these elements combine preferentially with carbon to form stable particles, thereby reducing the risk of forming chromium carbide
- use heat treatment, however this method is rarely used in practice.

Grades of stainless steel with a low carbon content (0,03% maximum) up to 20 mm thick should not suffer from intergranular corrosion after arc welding.

## **3.7.3 Corrosion in selected environments**

### ***Air***

Atmospheric environments vary, as do their effect on stainless steels. Rural atmospheres, uncontaminated by industrial fumes or coastal salt, are very mild in terms of corrosivity, even in areas of high humidity. Industrial and marine atmospheres are considerably more severe. Table 3.7 should be referred to for guidance on selecting suitable types of stainless steel.

The most common causes of atmospheric corrosion are metallic iron particles, arising from fabrication operations either in the workshop or at site, and chlorides originating from the sea, industrial processes or from calcium chloride used to make cement. Some deposited particles, although inert, are able to absorb weak acid solutions of sulfur dioxide from the atmosphere which may locally break down the passive film.

General appearance of exposed stainless steel is affected by surface finish (the smoother the better) and whether or not regular washing down is carried out (either intentionally or by rain).

### ***Sea water***

Sea water, including brackish water, contains high levels of chloride and hence is very corrosive, particularly when the water current is low (under about 1.5 m/s). At low current flows, severe pitting of grades 1.4301 and 1.4401 can occur. Also, these grades can suffer attack at crevices, whether these result from design details or from fouling organisms such as barnacles.

Salt spray may cause as much attack as complete immersion because the chloride concentration is raised by the evaporation of water or because of salt crystal deposits.

The possibility of severe bimetallic corrosion must be considered if stainless steel is used with other metals in the presence of sea water.

### ***Other waters***

Austenitic stainless steels usually perform satisfactorily in distilled, tap and boiler waters. Where acidity is high, grade 1.4401 is to be preferred, otherwise 1.4301 will usually suffice. Grade 1.4401 is also suggested as being more suitable where there are minor amounts of chloride present to avoid possible pitting and crevice corrosion problems. River water needs special consideration; biological and microbiological activity can cause pitting in austenitic stainless steels within a comparatively short time.

The possibility of erosion-corrosion should be considered for waters containing abrasive particles.

### ***Chemical environments***

The range of application of stainless steel in chemical environments is wide and it is not appropriate here to cover this subject in detail. It should be noted, however, that in many applications steels other than those considered in this Design Manual may be more suitable. The advice of a specialist corrosion engineer should be sought.

Charts published by manufacturers showing results of corrosion tests in various chemicals require careful interpretation. Although giving a guide to the resistance of a particular grade, service conditions (temperatures, pressures, concentrations, etc.) vary and will generally differ from the test conditions. Also, the effect of impurities and the degree of aeration can have a marked effect on results.

### ***Soils***

External corrosion of buried stainless steel is dependent on soil chemistry and resistivity. Soils differ in their corrosiveness depending on moisture level, pH, aeration, presence of chemical contamination, microbiological activity and surface drainage. Stainless steels generally perform well in a variety of soils and especially well in soils with high resistivity, although some pitting has occurred in low resistivity, moist soils. The presence of aggressive chemical species such as chloride ions as well as types of bacteria and stray current (caused by local direct current electric transportation systems such as railways or tram systems) can cause localized corrosion. The development of stray

current can be suppressed with a proper electrical insulation of the pipe (coatings or wrappings) and/or cathodic protection.

For grade selection purposes, it is recommended to consider the corrosion resistance of buried stainless steel firstly in relation to the presence of chloride ions and secondly according to the soil resistivity and pH, assuming poorly drained soils in all cases. Table 3.8 recommends suitable grades for different soil conditions.

**Table 3.8** *Stainless steel grades for use in different soil conditions*

Typical location	Soil condition		Grade of stainless steel
Inland	Cl	< 500 ppm	1.4301
	Resistivity	> 1000 ohm.cm	1.4404
	pH	> 4.5	
Marine – non-tidal zone	Cl	< 1500 ppm	
	Resistivity	> 1000 ohm.cm	1.4404
	pH	> 4.5	
Marine – tidal zone	Cl	< 6000 ppm	1.4410
	Resistivity	> 500 ohm.cm	1.4547
	pH	> 4.5	

Note:  
1.4410 is a duplex grade and 1.4547 is a super-austenitic grade. These grades are not generally used in construction applications and fall outside the scope of this Design Manual.

### ***Design for corrosion control***

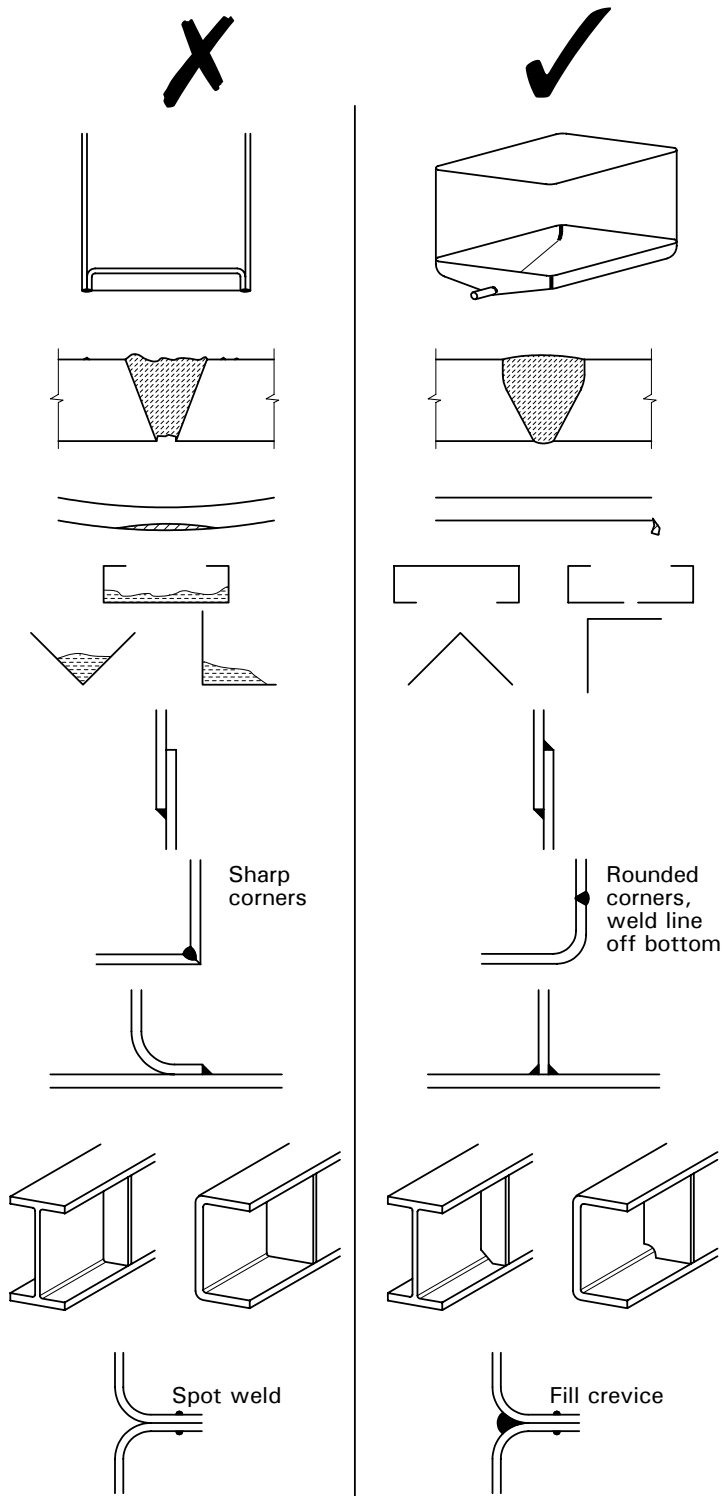
The most important step in preventing corrosion problems is selecting an appropriate grade of stainless steel with suitable fabrication procedures for the given environment. However, after specifying a particular steel, much can be achieved in realising the full potential of the steel's resistance by careful attention to detailing. Anti-corrosion actions should ideally be considered at the planning stage and during detailed design.

Table 3.9 gives a check list for consideration. Not all points would give the best detail from a structural strength point of view and neither are the points intended to be applied to all environments. In particular, in environments of low corrosivity or where regular maintenance is carried out, many would not be required. Figure 3.3 illustrates poor and good design features for durability.

**Table 3.9** *Design for corrosion control*

<p><b>Avoid dirt entrapment</b></p> <ul style="list-style-type: none"><li>• orientate angle and channel profiles to minimise the likelihood of dirt retention</li><li>• provide drainage holes, ensuring they are of sufficient size to prevent blockage</li><li>• avoid horizontal surfaces</li><li>• specify a small slope on gusset stiffeners which nominally lie in a horizontal plane</li><li>• use tubular and bar sections (seal tubes with dry gas or air where there is a risk of harmful condensates forming)</li><li>• specify smooth finishes.</li></ul>
<p><b>Avoid crevices</b></p> <ul style="list-style-type: none"><li>• use welded rather than bolted connections</li><li>• use closing welds or mastic fillers</li><li>• Preferably, dress/profile welds</li><li>• prevent biofouling.</li></ul>
<p><b>Reduce the likelihood of stress corrosion cracking in those specific environments where it may occur (see Section 3.7.2):</b></p> <ul style="list-style-type: none"><li>• minimise fabrication stresses by careful choice of welding sequence</li><li>• shot peen (but avoid the use of iron/steel shot).</li></ul>
<p><b>Reduce likelihood of pitting (see Section 10):</b></p> <ul style="list-style-type: none"><li>• remove weld spatter</li><li>• pickle stainless steel to remove unwanted welding products. Strongly oxidising chloride-containing reagents such as ferric chloride should be avoided; rather a pickling bath or a pickling paste, both containing a mixture of nitric acid and hydrofluoric acid, should be used. Welds should always be cleaned up to restore corrosion resistance.</li><li>• avoid pick-up of carbon steel particles (e.g. use workshop area and tools dedicated to stainless steel)</li><li>• follow a suitable maintenance programme.</li></ul>
<p><b>Reduce likelihood of bimetallic corrosion (see Section 3.7.2):</b></p> <ul style="list-style-type: none"><li>• provide electrical insulation</li><li>• use paints appropriately</li><li>• minimise periods of wetness</li><li>• use metals that are close to each other in electrical potential.</li></ul>





**Figure 3.3** *Poor and good design features for durability*

## 4 PROPERTIES OF SECTIONS

### 4.1 General

The recommendations in Sections 4 and 5 apply to cross-sections with elements complying with the dimensional limits of Section 4.2.

The width-to-thickness ratios of elements that are partly or wholly in compression determine whether they are subject to local buckling, with a consequential reduction in the resistance of the cross-section. Elements and cross-sections are classified as Class 1, 2, 3 or 4 depending on the susceptibility to local buckling and their rotation capacity (Class 1 and 2), see Section 4.3.

The reduced resistance of Class 4 cross-sections may be allowed for in design by the use of effective widths of elements, see Section 4.4.1.

Mid-line dimensions may only be used for calculating section properties of cold-formed members and sheeting. For other sections, the overall dimensions should be used. EN 1993-1-3 and EN 1993-1-5 permit mid-line dimensions to be used in calculating resistances. EN 1993-1-1 also allows the use of mid-line dimensions in calculating resistances in certain cases (see 6.2.1(9) but also 6.2.5(2) of EN 1993-1-1).

### 4.2 Maximum width-to-thickness ratios

Table 4.1 gives maximum width-to-thickness ratios for stainless steel elements.

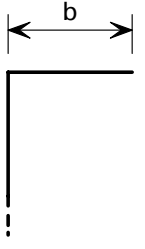
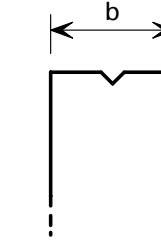
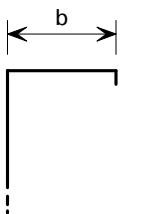
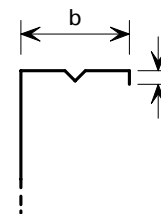
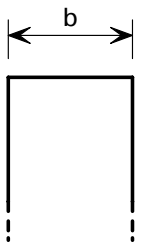
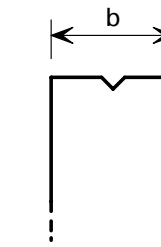
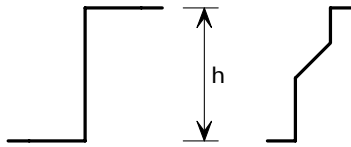
### 4.3 Classification of cross-sections

#### 4.3.1 General

In principle, stainless steel cross-sections may be classified in the same way as those of carbon steel. Four classes of cross-section are defined as follows:

- |         |  |
|---------|--|
| Class 1 | cross-sections are those which can form a plastic hinge with the rotation capacity required from plastic analysis.   |
| Class 2 | cross-sections are those which can develop their plastic moment resistance, but have limited rotation capacity.  |
| Class 3 | cross-sections are those in which the calculated stress in the extreme compression fibre of the steel member can reach its yield strength, but local buckling is liable to prevent development of the plastic moment resistance. |
| Class 4 | cross-sections are those in which local buckling will occur before the attainment of yield stress in one or more parts of the cross-section.   |

**Table 4.1** Maximum width-to-thickness ratios

<p>a) Flat element or intermediately stiffened element connected to a web along one edge with the other edge unsupported:</p>	$b/t \leq 50$		
<p>b) Flat element or intermediately stiffened element connected to a web along one edge and provided with a small simple lip along the other edge</p>	$b/t \leq 60$ $c/t \leq 50$		
<p>c) Flat element or intermediately stiffened element connected along both edges to webs or flanges:</p>	$b/t \leq 400$  $h/t \leq 400$		  
<p>Note: Flat elements supported as in a) above with <math>b/t</math> ratios greater than approximately 30 and flat elements supported otherwise with <math>b/t</math> ratios greater than approximately 75 are likely to develop visual distortion at serviceability design loads.</p>			

The classification of a cross-section depends on the highest (least favourable) class of its constituent parts that are partially or wholly in compression. It should be noted that the cross-section classification can vary according to the proportion of moment or axial load present and thus can vary along the length of a member.

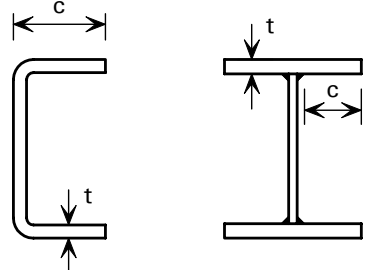
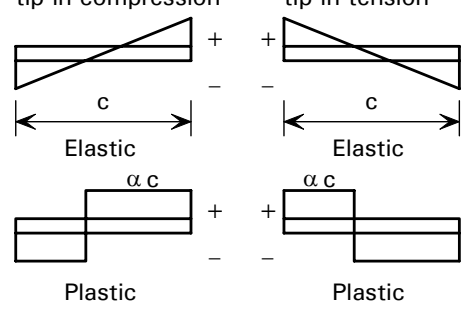
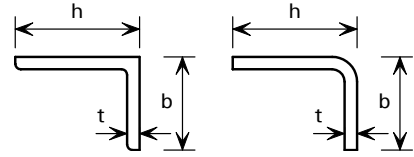
#### 4.3.2 Classification limits for parts of cross-sections

Sections are classified as Class 1, 2, or 3 depending on the limits set out in Table 4.2. Those sections which do not meet the criteria for Class 3 sections are classified as Class 4.

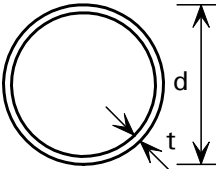
**Table 4.2** Maximum width-to-thickness ratios for compression parts

Internal compression parts				
<p>The diagram illustrates various cross-sections of internal compression parts. It shows an I-beam with dimensions <math>c</math> (flange width) and <math>t</math> (flange thickness), and a hollow section with dimensions <math>c</math> and <math>t</math>. Stress distribution graphs are shown for both elastic and plastic states. The elastic state shows a linear stress distribution with maximum stress <math>f_y</math> at the extreme fibers. The plastic state shows a rectangular stress distribution with maximum stress <math>f_y</math> and a partial yield stress <math>\alpha c</math> in the compression flange. The axis of bending is indicated for all sections.</p>				
Class	Part subject to bending	Part subject to compression	Part subject to bending and compression	
1	$c/t \leq 56,0\varepsilon$	$c/t \leq 25,7\varepsilon$	when $\alpha > 0,5$ : $c/t \leq 308\varepsilon/(13\alpha - 1)$  when $\alpha \leq 0,5$ : $c/t \leq 28\varepsilon/\alpha$	
2	$c/t \leq 58,2\varepsilon$	$c/t \leq 26,7\varepsilon$	when $\alpha > 0,5$ : $c/t \leq 320\varepsilon/(13\alpha - 1)$  when $\alpha \leq 0,5$ : $c/t \leq 29,1\varepsilon/\alpha$	
3	$c/t \leq 74,8\varepsilon$	$c/t \leq 30,7\varepsilon$	$c/t \leq 15,3\varepsilon\sqrt{k_\sigma}$ For $k_\sigma$ see 4.4.1	
$\varepsilon = \left[ \frac{235}{f_y} \frac{E}{210\,000} \right]^{0,5}$	Grade	1.4301	1.4401	1.4462
	$f_y$ (N/mm <sup>2</sup> )	210	220	460
	$\varepsilon$	1,03	1,01	0,698
Notes: For hollow sections, $c$ may conservatively be taken as $(h-2t)$ or $(b-2t)$ $E = 200\,000$ N/mm <sup>2</sup> $\alpha = \frac{1}{2} \left( 1 + \frac{N_{Ed}}{f_y c \sum t_w} \right)$ for sections which are symmetrical about the major axis				

**Table 4.2 (continued) Maximum width-to-thickness ratios for compression parts**

<u>Outstand flanges</u>				
		<p>Stress distributions (compression + ve) tip in compression      tip in tension</p> 		
Class	Type of section	Part subject to compression	Part subject to bending and compression	
			Tip in compression	Tip in tension
1	Cold formed	$c/t \leq 10,0\varepsilon$	$c/t \leq \frac{10\varepsilon}{\alpha}$	$c/t \leq \frac{10\varepsilon}{\alpha\sqrt{\alpha}}$
	Welded	$c/t \leq 9,0\varepsilon$	$c/t \leq \frac{9\varepsilon}{\alpha}$	$c/t \leq \frac{9\varepsilon}{\alpha\sqrt{\alpha}}$
2	Cold formed	$c/t \leq 10,4\varepsilon$	$c/t \leq \frac{10,4\varepsilon}{\alpha}$	$c/t \leq \frac{10,4\varepsilon}{\alpha\sqrt{\alpha}}$
	Welded	$c/t \leq 9,4\varepsilon$	$c/t \leq \frac{9,4\varepsilon}{\alpha}$	$c/t \leq \frac{9,4\varepsilon}{\alpha\sqrt{\alpha}}$
3	Cold formed	$c/t \leq 11,9\varepsilon$	$c/t \leq 18,1\varepsilon\sqrt{k_\sigma}$	For $k_\sigma$ see 4.4.1.
	Welded	$c/t \leq 11,0\varepsilon$	$c/t \leq 16,7\varepsilon\sqrt{k_\sigma}$	For $k_\sigma$ see 4.4.1.
<u>Angles</u>				
<p>Refer also to Outstand flanges Does not apply to angles in continuous contact with other components</p> 				
Class	Section in compression			
3	$h/t \leq 11,9 \varepsilon$ ; $(b + h)/2t \leq 9,1 \varepsilon$			
$\varepsilon = \left[ \frac{235}{f_y} \frac{E}{210\,000} \right]^{0,5}$	Grade	1.4301	1.4401	1.4462
	$f_y$ (N/mm <sup>2</sup> )	210	220	460
	$\varepsilon$	1,03	1,01	0,698
<p>Note: <math>E = 200\,000</math> N/mm<sup>2</sup></p> $\alpha = \frac{1}{2} \left( 1 + \frac{N_{Ed}}{f_y c \sum t_w} \right)$ <p>for sections which are symmetrical about the major axis</p>				

**Table 4.2 (continued) Maximum width-to-thickness ratios for compression parts**

<u>Tubular sections</u>				
				
Class	Section in bending	Section in compression		
1	$d/t \leq 50\varepsilon^2$	$d/t \leq 50\varepsilon^2$		
2	$d/t \leq 70\varepsilon^2$	$d/t \leq 70\varepsilon^2$		
3	$d/t \leq 280\varepsilon^2$ Note for $d/t > 280\varepsilon^2$ see EN 1993-1-6	$d/t \leq 90\varepsilon^2$ Note for $d/t > 90\varepsilon^2$ see EN1993-1-6		
$\varepsilon = \left[ \frac{235}{f_y} \frac{E}{210\,000} \right]^{0.5}$	Grade	1.4301	1.4401	1.4462
	$f_y$ (N/mm <sup>2</sup> )	210	220	460
	$\varepsilon$	1,03	1,01	0,698
Note: $E = 200\,000$ N/mm <sup>2</sup>				

## 4.4 Effective widths

### 4.4.1 Effective widths of elements in Class 4 cross-sections

The properties of Class 4 cross-sections may be established by calculation using the effective widths of the component parts in full or partial compression. Alternatively, testing may be utilised, see Section 9.

The effective area of a Class 4 cross-section in full or partial compression,  $A_{\text{eff}}$ , is the gross area of the cross-section minus the sum of the ineffective areas of each slender element making up the cross-section. The effective area of each Class 4 element is the effective breadth  $b_{\text{eff}}$  calculated below multiplied by the element thickness. When the cross-section is subject to bending, an effective moment of inertia  $I_{\text{eff}}$  and effective section modulus  $W_{\text{eff}}$  also need to be calculated.

The effective widths of elements in full or partial compression may be obtained from Table 4.3 for internal elements, and from Table 4.4 for outstand elements.

The effective widths of flange elements in compression may be based on the stress ratio  $\psi$  determined for the gross cross-section ( $\psi$  is defined in Tables 4.3 and 4.4). The effective width of a web element should be based on the stress

ratio  $\psi$  determined for a cross-section comprising the effective area of the compression flange but the gross area of the web and tension flange.

The reduction factor  $\rho$  may be calculated as follows:

Cold formed or welded internal elements:

$$\rho = \frac{0,772}{\bar{\lambda}_p} - \frac{0,125}{\bar{\lambda}_p^2} \quad \text{but } \leq 1 \quad (4.1a)$$

Cold formed outstand elements:

$$\rho = \frac{1}{\bar{\lambda}_p} - \frac{0,231}{\bar{\lambda}_p^2} \quad \text{but } \leq 1 \quad (4.1b)$$

Welded outstand elements:

$$\rho = \frac{1}{\bar{\lambda}_p} - \frac{0,242}{\bar{\lambda}_p^2} \quad \text{but } \leq 1 \quad (4.1c)$$

where  $\bar{\lambda}_p$  is the element slenderness defined as:

$$\bar{\lambda}_p = \frac{\bar{b}/t}{28,4\varepsilon\sqrt{k_\sigma}} \quad (4.2)$$

in which:

$t$  is the relevant thickness

$k_\sigma$  is the buckling factor corresponding to the stress ratio  $\psi$  from Table 4.3 or Table 4.4 as appropriate

$\bar{b}$  is the relevant width as follows:

$\bar{b} = d$  for webs (except RHS)

$\bar{b} =$  flat element width for webs of RHS, which can conservatively be taken as  $h-2t$

$\bar{b} = b$  for internal flange elements (except RHS)

$\bar{b} =$  flat element width for flanges of RHS, which can conservatively be taken as  $b-2t$

$\bar{b} = c$  for outstand flanges

$\bar{b} = h$  for equal leg angles and unequal leg angles

$\varepsilon$  is the material factor defined in Table 4.2.

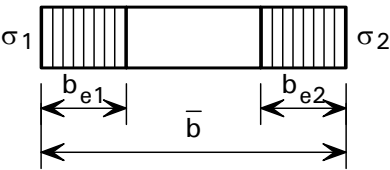
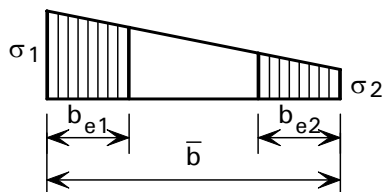
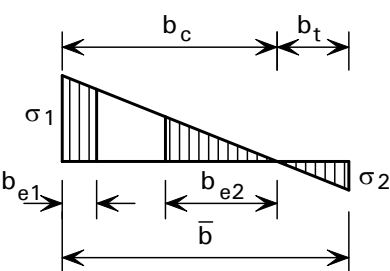
Generally, the neutral axis of the effective section will shift by a dimension  $e$  compared to the neutral axis of the gross section, see Figures 4.1 and 4.2. This should be taken into account when calculating the properties of the effective cross-section.

When the cross-section is subject to axial compression, the recommendations of Section 5.5.2 take account of the additional moment  $\Delta M_{Ed}$  given by:

$$\Delta M_{Ed} = N_{Ed} e_N$$

where  $e_N$  is the shift of the neutral axis when the cross-section is subject to uniform compression, see Figure 4.2.

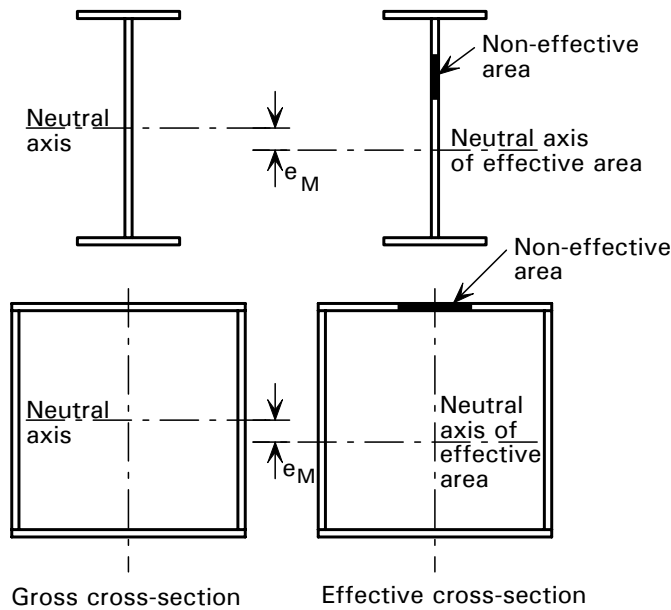
**Table 4.3** *Internal compression elements*

Stress distribution (compression positive)				Effective width $b_{eff}$		
				$\psi = 1:$ <hr/> $b_{eff} = \rho \bar{b}$  $b_{e1} = 0,5 b_{eff} \quad b_{e2} = 0,5 b_{eff}$		
				$1 > \psi \geq 0:$ <hr/> $b_{eff} = \rho \bar{b}$  $b_{e1} = \frac{2 b_{eff}}{5 - \psi} \quad b_{e2} = b_{eff} - b_{e1}$		
				$\psi < 0:$ <hr/> $b_{eff} = \rho b_c = \rho \bar{b} / (1 - \psi)$  $b_{e1} = 0,4 b_{eff} \quad b_{e2} = 0,6 b_{eff}$		
$\psi = \sigma_2 / \sigma_1$	1	$1 > \psi > 0$	0	$0 > \psi > -1$	-1	$-1 > \psi > -3$
Buckling factor $k_\sigma$	4,0	$8,2 / (1,05 + \psi)$	7,81	$7,81 - 6,29\psi + 9,78\psi^2$	23,9	$5,98 (1 - \psi)^2$

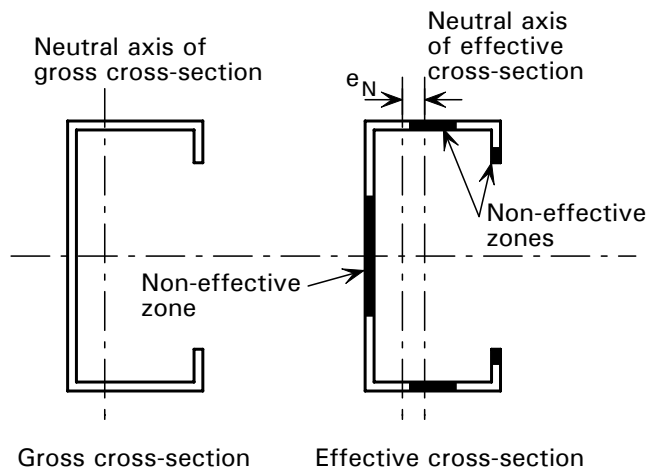


**Table 4.4** *Outstand compression elements*

Stress distribution (compression positive)			Effective width $b_{eff}$		
			$1 > \psi \geq 0:$ $b_{eff} = \rho c$		
			$\psi < 0:$ $b_{eff} = \rho b_c = \rho c / (1 - \psi)$		
$\psi = \sigma_2 / \sigma_1$	1	0	-1	$+1 \geq \psi \geq -3$	
Buckling factor $k_\sigma$	0,43	0,57	0,85	$0,57 - 0,21\psi + 0,07\psi^2$	
			$1 > \psi \geq 0:$ $b_{eff} = \rho c$		
			$\psi < 0:$ $b_{eff} = \rho b_c = \rho c / (1 - \psi)$		
$\psi = \sigma_2 / \sigma_1$	1	$1 > \psi > 0$	0	$0 > \psi > -1$	-1
Buckling factor $k_\sigma$	0,43	$0,578 / (\psi + 0,34)$	1,70	$1,7 - 5\psi + 17,1\psi^2$	23,8



**Figure 4.1** Class 4 cross-section subject to bending moment



**Figure 4.2** Class 4 cross-section subject to compression

#### 4.4.2 Effects of shear lag

Shear lag in flanges may be neglected if  $b_0 < L_e/50$ , where  $b_0$  is taken as the flange outstand or half the width of an internal element and  $L_e$  is the length between points of zero bending moment. Where this limit for  $b_0$  is exceeded, the effects of shear lag in flanges should be considered; the guidance for carbon steel in EN 1993-1-5 is applicable. Note that EN 1993-1-5 requires that shear lag be taken into account at both the ultimate and the serviceability limit states.

#### 4.4.3 Flange curling

The effect on the load bearing resistance of curling (i.e. inward curvature towards the neutral plane) of a very wide flange in a profile subjected to flexure, or of a flange in an arched profile subjected to flexure in which the concave side is in compression, should be taken into account unless such curling is less than 5% of the depth of the profile cross-section. If the curling is larger,

then the reduction in load bearing resistance, for instance due to a decrease in the length of the lever arm for parts of the wide flanges, and the possible effect of the bending of the webs should be taken into account.

Width-to-thickness ratios of flanges in typical stainless steel beams are unlikely to be susceptible to flange curling. Where required, the guidance for carbon steel in EN 1993-1-3 is applicable.

## 4.5 Stiffened elements

### 4.5.1 Edge stiffeners

The guidance for carbon steel in EN 1993-1-3 is applicable.

### 4.5.2 Intermediate stiffeners

The guidance for carbon steel in EN 1993-1-3 is applicable.

### 4.5.3 Trapezoidal sheeting profiles with intermediate flange stiffeners

The effective cross-section of a flange with intermediate stiffeners and subject to uniform compression should be assumed to consist of the reduced effective areas  $A_{s,red}$  including two strips of width  $0,5b_{eff}$  or  $15t$  adjacent to the stiffener, see Figure 4.3 and 4.4.

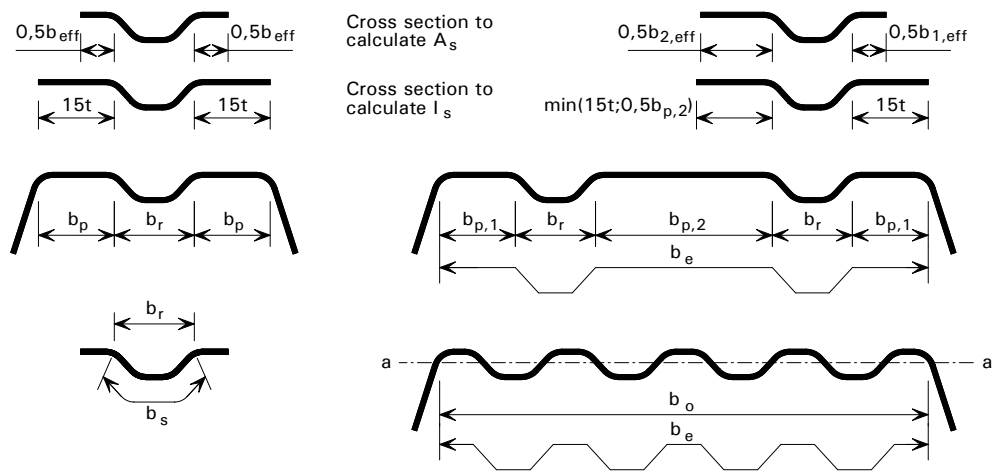
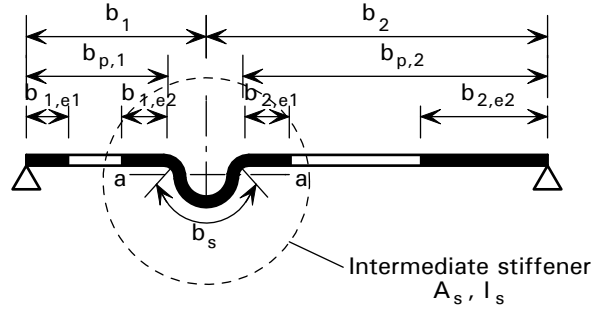


Figure 4.3 Compression flange with one, two or multiple stiffeners



**Figure 4.4** *Intermediate stiffener*

For one central flange stiffener, the elastic critical buckling stress  $\sigma_{cr,s}$  (used for determining  $\bar{\lambda}_d$ ) should be obtained from:

$$\sigma_{cr,s} = \frac{4,2k_w E}{A_s} \sqrt{\frac{I_s t^3}{4b_p^2(2b_p + 3b_s)}} \quad (4.3)$$

where:

- $b_p$  is the notional flat width of the plane element shown in Figure 4.3, 4.4 and 4.5
- $b_s$  is the stiffener width, measured around the perimeter of the stiffener, see Figure 4.3, 4.4 and 4.5
- $A_s$  is the cross-sectional area of the stiffener cross-section according to Figure 4.3, 4.4 and 4.5
- $I_s$  is the second moment of area of the stiffener cross-section according to Figure 4.3, 4.4 and 4.5
- $k_w$  is a coefficient that allows for partial rotational restraint of the stiffened flange by the webs or other adjacent elements, see below. For the calculation of the effective cross-section in axial compression the value  $k_w = 1,0$ .

For two symmetrically placed flange stiffeners, the elastic critical buckling stress  $\sigma_{cr,s}$  should be obtained from:

$$\sigma_{cr,s} = \frac{4,2k_w E}{A_s} \sqrt{\frac{I_s t^3}{8b_1^2(3b_e - 4b_1)}} \quad (4.4)$$

in which:

$$b_e = 2b_{p,1} + b_{p,2} + 2b_s \quad (4.5)$$

$$b_1 = b_{p,1} + 0,5b_r \quad (4.6)$$

where:

- $b_{p,1}$  is the notional flat width of an outer plane element, as shown in Figure 4.4,
- $b_{p,2}$  is the notional flat width of the central plane element, as shown in Figure 4.4
- $b_r$  is the overall width of a stiffener, see Figure 4.3.

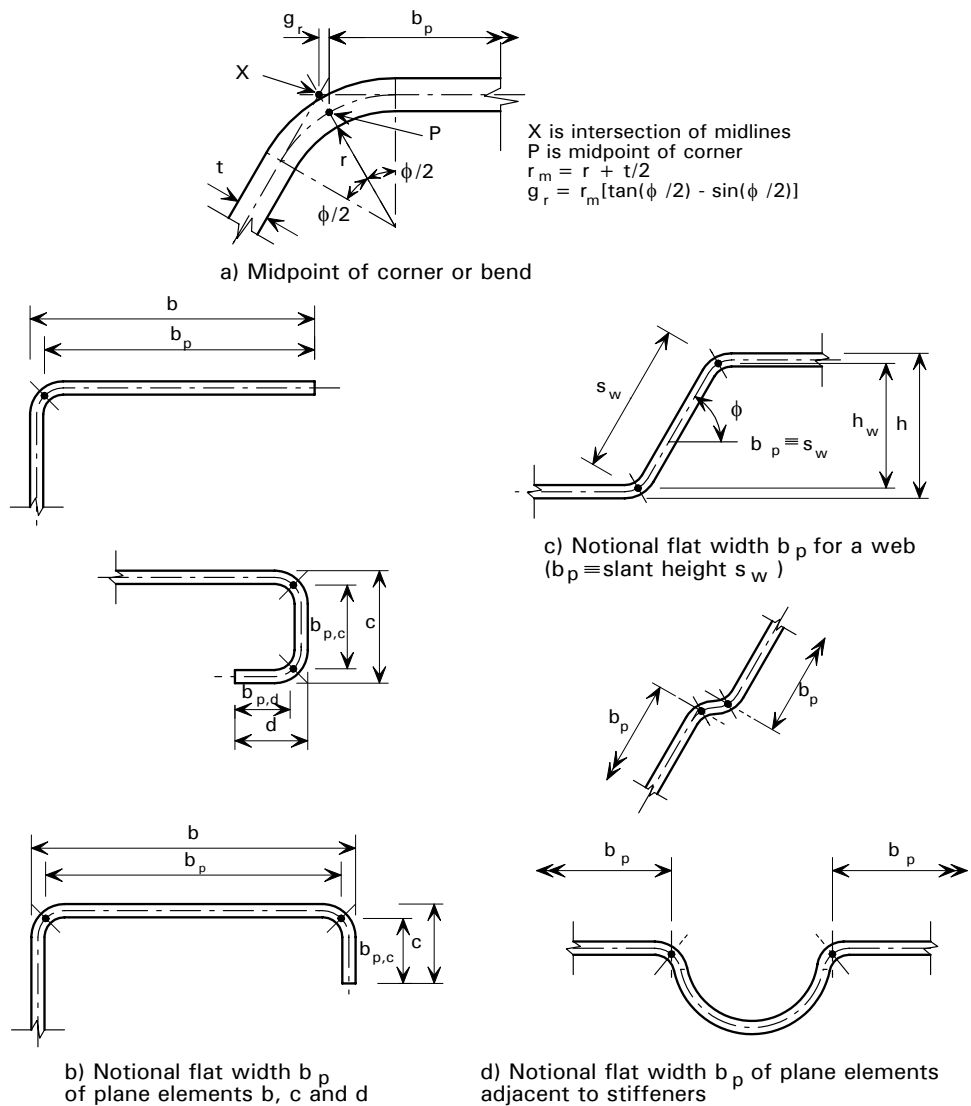
The value of  $k_w$  may be calculated from the compression flange buckling wavelength  $l_b$  as follows:

$$\text{if } \frac{l_b}{s_w} \geq 2, \quad k_w = k_{w0} \quad (4.7)$$

$$\text{if } \frac{l_b}{s_w} < 2, \quad k_w = k_{w0} - (k_{w0} - 1) \left[ \frac{2l_b}{s_w} - \left( \frac{l_b}{s_w} \right)^2 \right] \quad (4.8)$$

where:

$s_w$  is the slant height of the web, see Figure 4.5.



**Figure 4.5** Notional widths of plane elements  $b_p$  allowing for corner radii

Alternatively, the rotational restraint coefficient  $k_w$  may conservatively be taken as equal to 1,0 corresponding to a pin-jointed condition.

The values of  $l_b$  and  $k_{w0}$  may be determined from:

a) for a compression flange with one intermediate stiffener:

$$l_b = 3,07 \sqrt[4]{\frac{I_s b_p^2 (2b_p + 3b_s)}{t^3}} \quad (4.9)$$

$$k_{wo} = \sqrt{\frac{s_w + 2b_d}{s_w + 0,5b_d}} \quad (4.10)$$

$$\text{with } b_d = 2b_p + b_s \quad (4.11)$$

b) for a compression flange with two or three intermediate stiffeners:

$$l_b = 3,65 \sqrt[4]{\frac{I_s b_1^2 (3b_e - 4b_1)}{t^3}} \quad (4.12)$$

$$k_{wo} = \sqrt{\frac{(2b_e + s_w)(3b_e - 4b_1)}{b_1(4b_e - 6b_1) + s_w(3b_e - 4b_1)}} \quad (4.13)$$

The reduced effective area of the stiffener  $A_{s,red}$  allowing for distortional buckling should be taken as:

$$A_{s,red} = \chi_d A_s \frac{f_y / \gamma_{MO}}{\sigma_{com,ser}} \quad \text{but } A_{s,red} \leq A_s \quad (4.14)$$

where:

$\sigma_{com,ser}$  is the maximum compressive stress in the stiffener (calculated on the basis of the effective cross-section) under serviceability limit state loading.

If the webs are unstiffened, the reduction factor  $\chi_d$  should be obtained from the following:

$$\text{if } \bar{\lambda}_d \leq 0,65, \quad \chi_d = 1,0 \quad (4.15)$$

$$\text{if } 0,65 < \bar{\lambda}_d < 1,38, \quad \chi_d = 1,47 - 0,723\bar{\lambda}_d \quad (4.16)$$

$$\text{if } \bar{\lambda}_d \geq 1,38, \quad \chi_d = \frac{0,66}{\bar{\lambda}_d} \quad (4.17)$$

where  $\bar{\lambda}_d = \sqrt{f_y / \sigma_{cr,s}}$ .

If the webs are also stiffened, reference should be made to EN 1993-1-3.

In determining effective section properties, the reduced effective area  $A_{s,red}$  should be represented by using a reduced thickness  $t_{red} = t A_{s,red} / A_s$  for all the elements included in  $A_s$ .

## 4.6 Calculation of section properties

### 4.6.1 General

The calculation of section properties should be carried out in accordance with normal good practice taking into account any reduction in the gross area due to

local buckling or holes as necessary. Thinning of material at cold formed corners can be neglected, because of the strength increase afforded by work hardening.

#### 4.6.2 Influence of rounded corners

The influence of rounded corners on cross-section resistance may be neglected if the internal radius  $r \leq 5t$  and  $r \leq 0.10b_p$  and the cross-section may be assumed to consist of plane elements with sharp corners. For cross-section stiffness properties the influence of rounded corners should always be taken into account.

The influence of rounded corners on section properties may be taken into account with sufficient accuracy by reducing the properties calculated for an otherwise similar cross-section with sharp corners, see Figure 4.6, using the following approximations:

$$A_g = A_{g,sh} (1 - \delta) \quad (4.18)$$

$$I_g = I_{g,sh} (1 - 2\delta) \quad (4.19)$$

$$I_w = I_{w,sh} (1 - 4\delta) \quad (4.20)$$

in which:

$$\delta = 0,43 \sum_{j=1}^n r_j \frac{\phi_j}{90^\circ} / \sum_{i=1}^m b_{p,i} \quad (4.21)$$

where:

$A_g$  is the area of the gross cross-section

$A_{g,sh}$  is the value of  $A_g$  for a cross-section with sharp corners

$b_{p,i}$  is the notional flat width of the plane element  $i$  for a cross-section with sharp corners

$I_g$  is the second moment of area of the gross cross-section

$I_{g,sh}$  is the value of  $I_g$  for a cross-section with sharp corners

$I_w$  is the warping constant of the gross cross-section

$I_{w,sh}$  is the value of  $I_w$  for a cross-section with sharp corners

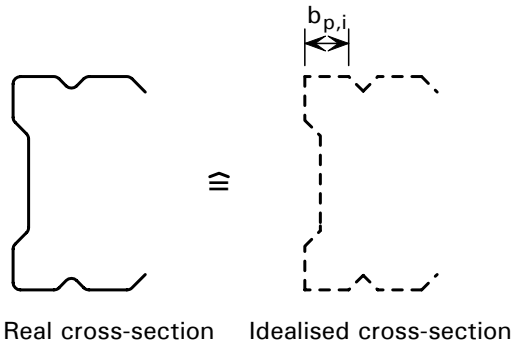
$\phi_j$  is the angle between two plane elements

$m$  is the number of plane elements

$n$  is the number of curved elements

$r_j$  is the internal radius of curved element  $j$ .

The reductions given above may also be applied in calculating the effective section properties  $A_{eff}$ ,  $I_{y,eff}$ ,  $I_{z,eff}$  and  $I_{w,eff}$ , provided that the notional flat widths of the plane elements are measured to the points of intersection of their midlines.



**Figure 4.6** *Real and idealised cross-section*

### 4.6.3 Gross cross section

When calculating gross cross section properties, holes for fasteners need not be deducted but allowance should be made for larger openings.

### 4.6.4 Net section

The net area of a section or element of a section should be taken as its gross area less appropriate deductions for all openings, including holes for fasteners. In the deductions for fasteners, the nominal hole diameter should be used.

Provided that the fastener holes are not staggered, the total area to be deducted for fastener holes should be the maximum sum of the sectional areas of the holes in any cross-section perpendicular to the member axis (see failure plane (2) in Figure 4.7).

When the fastener holes are staggered, the total area to be deducted should be the greater of:

- the deduction for non-staggered holes

- $t \left( nd_0 - \sum \frac{s^2}{4p} \right)$

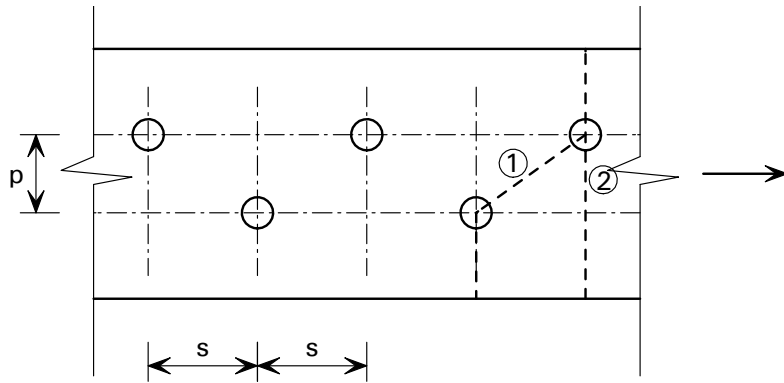
where:

- $s$  is the staggered pitch, the spacing of the centres of two consecutive holes in the chain measured parallel to the member axis
- $p$  is the spacing of the centres of the same two holes measured perpendicular to the member axis
- $t$  is the thickness
- $n$  is the number of holes extending in any diagonal or zig-zag line progressively across the member or part of the member, see Figure 4.7
- $d_0$  is the diameter of the hole.

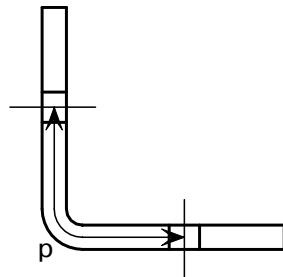
For sections such as angles with holes in both legs, the gauge should be measured along the centre of the thickness of the material, see Figure 4.8.

For angles connected by one leg, see Section 6.2.





**Figure 4.7** Staggered holes and critical fracture lines 1 and 2



**Figure 4.8** Gauge length for angle with holes in both legs

## 4.7 Resistances of cross-sections

### 4.7.1 General

This Section relates to the resistance of cross-sections only; a check on possible buckling modes is also required to establish member resistance. Buckling of members is addressed in Section 5. The  $\gamma_M$  factors used in this Section are given in Table 2.1.

The work-hardening associated with cold forming operations during fabrication (see Section 3.2.2) will generally increase the cross-sectional resistance but sufficient data are not yet available for stainless steel to enable design recommendations to be made. It is suggested that when the benefits of work-hardening are to be utilised, the cross-sectional resistance should be established by tests (see Section 9).

Under exceptional circumstances, it may be permissible to utilise the strain hardening material property of stainless steel in design, see Section 4.7.7.

### 4.7.2 Cross-sections subject to tension

The resistance of cross-sections subject to uniform tensile stresses only,  $N_{t,Rd}$ , may be taken as the smaller of:

- a) the design plastic resistance of the gross cross-section

$$N_{pl,Rd} = \frac{A_g f_y}{\gamma_{M0}} \quad (4.22)$$

- b) the design ultimate resistance of the net cross-section at holes for fasteners

$$N_{u,Rd} = \frac{k_r A_{net} f_u}{\gamma_{M2}} \quad (4.23)$$

where:

$A_g$  is the gross area

$A_{net}$  is the net cross-sectional area (see Section 4.6.4)

$f_y$  is the characteristic yield strength (generally taken as the minimum specified 0,2% proof strength, see Table 3.1)

$f_u$  is the characteristic ultimate tensile strength (generally taken as the minimum specified value, see Table 3.1)

$$k_r = [1 + 3r(d_0 / u - 0,3)] \text{ but } k_r \leq 1,0 \quad (4.24)$$

$r$  = [number of bolts at the cross-section]/[total number of bolts in the connection]

$d_0$  is the nominal bolt hole diameter

$$u = 2e_2 \text{ but } u \leq p_2.$$

#### 4.7.3 Cross-sections subject to compression

The resistance of a cross-section subject to compression,  $N_{c,Rd}$ , with a resultant acting through the centroid of the gross section (for Class 1, 2 and 3 cross-sections) or the effective section (Class 4 cross-sections) may be taken as:

$$N_{c,Rd} = A_g f_y / \gamma_{M0} \quad \text{for Class 1, 2 or 3 cross-sections} \quad (4.25)$$

$$N_{c,Rd} = A_{eff} f_y / \gamma_{M0} \quad \text{for Class 4 cross-sections} \quad (4.26)$$

Note: Class 4 sections which are not doubly symmetric should be assessed in accordance with 4.7.6 to account for the additional bending moment  $\Delta M_{Ed}$  due to the eccentricity of the centroidal axial of the effective sections, see Section 4.4.1.

#### 4.7.4 Cross-sections subject to bending moment

In the absence of shear and axial forces, the design moment resistance of a cross-section subject to a uniaxial moment,  $M_{c,Rd}$ , should be taken as:

$$M_{c,Rd} = W_{pl} f_y / \gamma_{M0} \quad \text{for Class 1 or 2 cross-sections} \quad (4.27)$$

$$M_{c,Rd} = W_{el,min} f_y / \gamma_{M0} \quad \text{for Class 3 cross-sections} \quad (4.28)$$

$$M_{c,Rd} = W_{eff,min} f_y / \gamma_{M0} \quad \text{for Class 4 cross-sections} \quad (4.29)$$

where:

$W_{pl}$  is the plastic section modulus

$W_{el,min}$  is the elastic section modulus corresponding to the fibre with the maximum elastic stress (but see Section 4.1 for cold formed cross-sections)

$W_{eff,min}$  is the elastic modulus of effective section corresponding to the fibre with the maximum elastic stress (but see Section 4.1 for cold formed cross-sections).

For cross-sections where bending is applied about both axes, see Section 4.7.6.

#### 4.7.5 Cross-sections subject to shear

The plastic shear resistance of a cross-section,  $V_{pl,Rd}$  may generally be taken as:

$$V_{pl,Rd} = A_v (f_y / \sqrt{3}) / \gamma_{M0} \quad (4.30)$$

where:

$A_v$  is the shear area, which may be taken as follows:

- a) rolled I and H sections, load parallel to web  
 $A - 2bt_f + (t_w + 2r)t_f$  but not less than  $\eta h_w t_w$
- b) rolled channel sections, load parallel to web  
 $A - 2bt_f + (t_w + r)t_f$
- c) rolled T-section, load parallel to web  $0,9(A - bt_f)$
- d) welded I, H and box sections, load parallel to web  $\eta \sum (h_w t_w)$
- e) welded I, H, channel and box section, load parallel to flanges  
 $A - \sum (h_w t_w)$
- f) rolled rectangular hollow sections of uniform thickness
  - i. load parallel to depth  $Ah/(b + h)$
  - ii. load parallel to width  $Ab/(b + h)$
- g) circular hollow sections and tubes of uniform thickness  $2A / \pi$

where:

- $A$  is the cross-sectional area
- $b$  is the overall breadth
- $h$  is the overall depth
- $h_w$  is the depth of the web
- $r$  is the root radius
- $t_f$  is the flange thickness
- $t_w$  is the web thickness (if the web thickness is not constant,  $t_w$  should be taken as the minimum thickness).
- $\eta$  see EN 1993-1-5. (EN 1993-1-4 recommends  $\eta = 1,20$ .)

Note: The same value of  $\eta$  should be used for calculating the shear buckling resistance as is used for calculating the plastic shear resistance.

The resistance to shear buckling should be also checked, see Section 5.4.3.

#### 4.7.6 Cross-sections subject to combination of loads

When an axial force is present, allowance should be made for its effect on the plastic moment resistance. For Class 1 and 2 cross sections, the following criterion should be satisfied:

$$M_{Ed} \leq M_{N,Rd} \quad (4.31)$$

where:

$M_{N,Rd}$  is the design plastic moment resistance reduced due to the axial force  $N_{Ed}$ .

For doubly symmetrical I- and H-sections or other flange sections, allowance need not be made for the effect of the axial force on the plastic resistance moment about the y-y axis when both the following criteria are satisfied:

$$N_{Ed} \leq 0,25N_{pl,Rd} \quad \text{and} \quad (4.32a)$$

$$N_{Ed} \leq 0,5h_w t_w f_y / \gamma_{M0} \quad (4.32b)$$

In the absence of shear force, for Class 3 and Class 4 cross-sections the maximum longitudinal stress should satisfy the criterion:

$$\sigma_{x,Ed} \leq f_y / \gamma_{M0} \quad (4.33)$$

where:

$\sigma_{x,Ed}$  is the design value of the local longitudinal stress due to moment and axial force, taking account of fastener holes where relevant.

For Class 4 cross-sections, the following criterion should also be met:

$$\frac{N_{Ed}}{A_{eff} f_y / \gamma_{M0}} + \frac{M_{y,Ed} + N_{Ed} e_{Ny}}{W_{eff,y,min} f_y / \gamma_{M0}} + \frac{M_{z,Ed} + N_{Ed} e_{Nz}}{W_{eff,z,min} f_y / \gamma_{M0}} \leq 1 \quad (4.34)$$

where:

$A_{eff}$  is the effective area of the cross-section when subjected to uniform compression

$W_{eff,min}$  is the effective section modulus of the cross-section when subjected only to moment about the relevant axis

$e_N$  is the shift of the relevant centroidal axis when the cross-section is subjected to compression only.

Note that for angles, the y and z axes in the above should be taken as the u and v axes respectively.

When  $V_{Ed}$  exceeds 50% of  $V_{pl,Rd}$ , the design resistance of the cross-section to combinations of moment and axial force should be calculated using a reduced yield strength  $(1 - \rho) f_y$  for the shear area, where  $\rho = (2V_{Ed} / V_{pl,Rd} - 1)^2$ .

#### 4.7.7 Utilisation of strain hardening behaviour

In certain circumstances, such as beams under short term accidental loads, it is permissible to recognise the benefits of the strain hardening properties of stainless steel more fully in design.

This may be achieved by utilising an enhanced proof stress,  $\sigma_0$ , in place of the 0,2% proof stress  $f_y$  in all calculations. It is recommended that in the absence of a more detailed appraisal, perhaps involving non-linear finite element analysis, the following restrictions should be observed:

- The cross-section should be of Class 1 or Class 2 as calculated by using  $\sigma_0$  in place of  $f_y$  when calculating  $\varepsilon$  in Table 4.2.
- The cross-section is subject to major axis bending only.
- The member concerned is not subject to instability caused by any form of buckling (flexural, torsional, lateral-torsional or distortional - see Section 5), again using  $\sigma_0$  in all calculations.
- Connections to adjacent members and the members themselves are sufficiently strong to realise the enhanced resistance of the member.

Particular attention should be given to assessing connection strength requirements.

For Class 3 and 4 cross-sections, enhanced strengths may be used provided these values are verified by testing in accordance with Section 9.

## 5 MEMBER DESIGN

### 5.1 Introduction

The design checks required for stainless steel members are similar to those required for carbon steel members. It is recommended that the forces and moments in the members are derived from an elastic global analysis.

In addition to the cross-sectional resistance, see Section 4, consideration should be given to overall buckling of members, as addressed in this section.

A possible design approach for checking against buckling in stainless steel members is to use the tangent modulus corresponding to the buckling stress instead of the initial modulus as used in carbon steel rules. Assuming similar levels of geometric and residual stress imperfections in carbon steel and stainless steel members, this generally leads to satisfactory results when it is based on validated carbon steel rules. This approach is therefore available to the designer. However, it requires iterative solution techniques and therefore has been avoided in this Design Manual except in some cases when it has been used to derive effective design curves for use with the initial modulus. Instead, emphasis has been given to calibrating against available experimental data.

The following subsections are intended for use with singly, doubly or point-symmetric uniform sections. The resistance of members not possessing any axis of symmetry should be verified by appropriate tests.

### 5.2 Tension members

Members subject to tension only do not suffer any instability due to buckling. Their design may therefore be based only on the cross-section resistance, see Section 4.7.2, and the resistance of their connections, see Section 6.

For an angle connected by one leg or other unsymmetrically connected members:

$$N_{t,Rd} = N_{pl,Rd} \leq N_{u,Rd} \quad (5.1)$$

where the terms are defined in Section 4.7.2 and  $N_{u,Rd}$  is determined from Section 6.2.3, Equations 6.6, 6.7 or 6.8.

### 5.3 Compression members

#### 5.3.1 General

Members in compression are susceptible to a number of possible buckling modes including:

- Plate buckling (Class 4 sections only)
- Flexural buckling
- Torsional buckling
- Torsional-flexural buckling.

### ***Doubly symmetric cross-sections (CHS, RHS, I sections etc.)***

Doubly symmetric cross-sections need not be checked for torsional-flexural buckling, since the shear centre coincides with the centroid of the cross-section. However, torsional buckling may be critical.

Circular and square hollow sections will not fail by torsional buckling.

For the range of rectangular hollow section sizes typically used in construction, torsional buckling will not be critical. Torsional buckling in rectangular hollow sections need only be considered for rectangular hollow sections with unusually high  $h/b$  ratios.

### ***Singly symmetric cross-sections (equal-leg angles, channels etc.)***

It is necessary to check sections such as single channels and equal-leg angles for torsional-flexural buckling as the shear centre does not coincide with the centroid of the cross-section.

### ***Point symmetric cross-sections (Z-sections, cruciform sections etc.)***

Torsional buckling may be the critical buckling mode for these sections.

## **5.3.2 Plate buckling**

Plate buckling within Class 4 sections is taken into account by the use of an effective cross-section area. Note that the additional moment caused by the shift in neutral axis of the effective section from that of the gross section in asymmetric Class 4 cross-sections should be considered in accordance with Section 5.5.

## **5.3.3 Flexural buckling**

The resistance to flexural buckling should be determined from:

$$N_{b,Rd} = \chi A f_y / \gamma_{M1} \quad \text{for Class 1, 2 and 3 cross-sections} \quad (5.2a)$$

$$N_{b,Rd} = \chi A_{\text{eff}} f_y / \gamma_{M1} \quad \text{for Class 4 cross-sections} \quad (5.2b)$$

where:

$A_{\text{eff}}$  is the effective area of Class 4 cross-section

$A$  is the gross area

$\chi$  is the reduction factor accounting for buckling, given by:

$$\chi = \frac{1}{\varphi + [\varphi^2 - \bar{\lambda}^2]^{0,5}} \leq 1 \quad (5.3)$$

in which:

$$\varphi = 0,5 \left( 1 + \alpha(\bar{\lambda} - \bar{\lambda}_0) + \bar{\lambda}^2 \right) \quad (5.4)$$

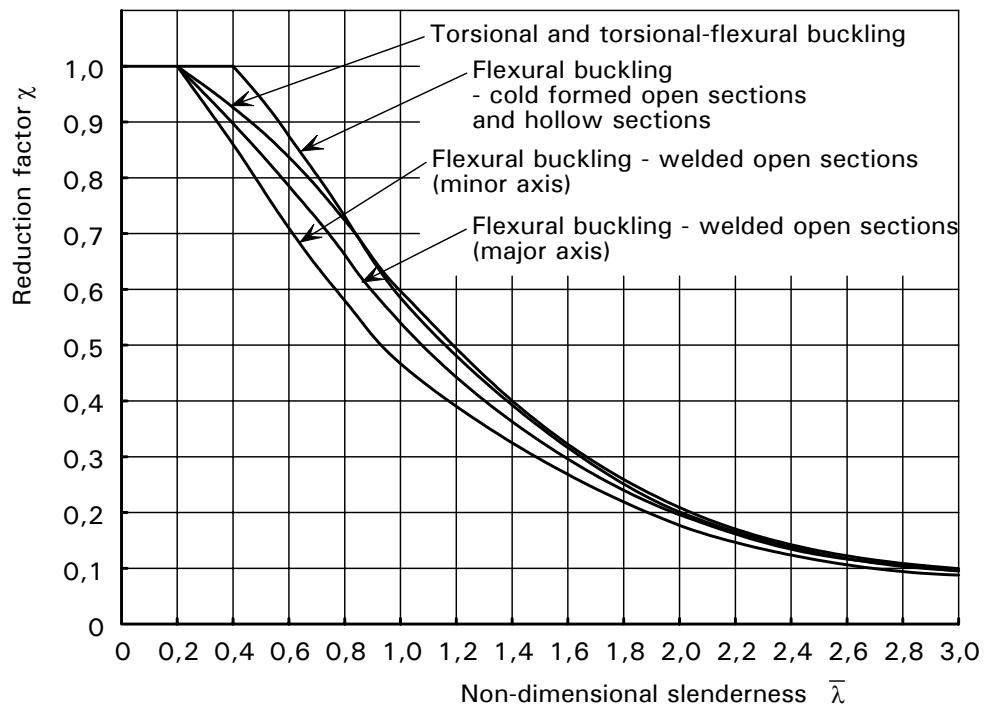
$$\bar{\lambda} = \sqrt{\frac{A f_y}{N_{cr}}} = \frac{L_{cr}}{i} \frac{1}{\pi} \sqrt{\frac{f_y}{E}} \quad \text{for Class 1, 2 and 3 cross-sections} \quad (5.5a)$$

$$\bar{\lambda} = \sqrt{\frac{A_{\text{eff}} f_y}{N_{cr}}} = \frac{L_{cr}}{i} \frac{1}{\pi} \sqrt{\frac{f_y \frac{A_{\text{eff}}}{A}}{E}} \quad \text{for Class 4 cross-sections} \quad (5.5b)$$

where:

- $\alpha$  is the imperfection factor defined in Table 5.1
- $N_{cr}$  is the elastic critical force for the relevant buckling mode based on the gross cross sectional properties
- $\bar{\lambda}_0$  is the limiting non-dimensional slenderness defined in Table 5.1
- $L_{cr}$  is the buckling length in the buckling plane considered, determined taking into account the boundary conditions
- $i$  is the radius of gyration about the relevant axis, determined using the properties of the gross cross section.

The buckling curves are shown in Figure 5.1. The values for  $\alpha$  and  $\bar{\lambda}_0$  in Table 5.1 do not apply to hollow sections which are annealed after fabrication. For non-dimensional slenderness  $\bar{\lambda} \leq \bar{\lambda}_0$  or for  $\frac{N_{Ed}}{N_{cr}} \leq \bar{\lambda}_0^2$  the buckling effects may be ignored and only cross sectional checks apply.



**Figure 5.1** *Buckling curves for flexural, torsional and torsional-flexural buckling*

The determination of the buckling length should be based upon structural mechanics principles, taking boundary conditions into account.



**Table 5.1** Values of  $\alpha$  and  $\bar{\lambda}_0$  for flexural, torsional and torsional-flexural buckling

Buckling mode	Type of member	$\alpha$	$\bar{\lambda}_0$
Flexural	Cold formed open sections	0,49	0,40
	Hollow sections (welded and seamless)	0,49	0,40
	Welded open sections (major axis)	0,49	0,20
	Welded open sections (minor axis)	0,76	0,20
Torsional and torsional-flexural	All members	0,34	0,20

### 5.3.4 Torsional and torsional-flexural buckling

The resistance to these buckling modes should be determined according to Section 5.3.3 but substituting  $\bar{\lambda}$  by  $\bar{\lambda}_T$ , as given by Equations 5.6 and 5.7, and taking  $\alpha = 0,34$  and  $\bar{\lambda}_0 = 0,2$ .

$$\bar{\lambda}_T = \sqrt{\frac{Af_y}{N_{cr}}} \text{ for Class 1, 2 and 3 cross-sections} \quad (5.6a)$$

$$\bar{\lambda}_T = \sqrt{\frac{A_{eff}f_y}{N_{cr}}} \text{ for Class 4 cross-sections} \quad (5.6b)$$

in which:

$$N_{cr} = N_{cr,TF} \text{ and } N_{cr} < N_{cr,T}$$

where:

$N_{cr,T}$  is the elastic critical torsional buckling force

$$N_{cr,T} = \frac{1}{i_o^2} \left( GI_t + \frac{\pi^2 EI_w}{l_T^2} \right) \quad (5.7a)$$

$N_{cr,TF}$  is the elastic critical torsional-flexural buckling force.

For cross-sections that are symmetrical about the y-y axis (e.g.  $z_o = 0$ )

$$N_{cr,TF} = \frac{N_{cr,y}}{2\beta} \left[ 1 + \frac{N_{cr,T}}{N_{cr,y}} - \sqrt{\left( 1 - \frac{N_{cr,T}}{N_{cr,y}} \right)^2 + 4 \left( \frac{y_o}{i_o} \right)^2 \frac{N_{cr,T}}{N_{cr,y}}} \right] \quad (5.7b)$$

in which:

$$i_o^2 = i_y^2 + i_z^2 + y_o^2 + z_o^2$$

$i_y$  and  $i_z$  are the radii of gyration of the gross cross-section about the y and z axes respectively

$y_o$  and  $z_o$  are the shear centre co-ordinates with respect to the centroid of the gross cross-section

$G$  is the shear modulus

$l_T$  is the buckling length of the member for torsional buckling (see EN 1993-1-3)

$I_T$  is the torsional constant of the gross cross-section

$I_W$  is the warping constant of the gross cross-section

$$\beta = 1 - \left( \frac{y_o}{i_o} \right)^2$$

$N_{cr,y}$  and  $N_{cr,z}$  are the elastic critical axial force for flexural buckling about the y-y and z-z axes respectively.

For a doubly symmetric cross-section, the shear centre coincides with the centroid, therefore  $y_o = 0$  and  $z_o = 0$  and

$$N_{cr,TF} = N_{cr,T} \text{ provided } N_{cr,T} < N_{cr,y} \text{ and } N_{cr,T} < N_{cr,z}.$$

Note that for angles, the y and z axes in the above should be taken as the u and v axes respectively.

## 5.4 Flexural members

### 5.4.1 General

A member is in simple bending under loads acting normal to the longitudinal axis if it is connected in such a way as to eliminate twisting or tensile or compressive end loading.

The following criteria should be considered for establishing the moment resistance of a beam:

- Yielding of the cross-section (see Section 4.7)
- Plate buckling (Class 4 section only – see Section 4.7)
- Lateral-torsional buckling (see Section 5.4.2)
- Shear buckling (see Section 5.4.3)
- Local strength at points of loading or reaction (see Section 5.4.4).

Note that for flexural members, the effects of shear lag and flange curling may have to be accounted for in design, see Sections 4.4.2 and 4.4.3.

Biaxial bending should be treated as described in Section 5.5.2.

### 5.4.2 Lateral-torsional buckling

The possibility of lateral-torsional buckling may be discounted for the following classes of member:

- beams subject to bending only about the minor axis
- beams laterally restrained throughout their length by adequate bracing
- beams where the lateral non-dimensional slenderness parameter  $\bar{\lambda}_{LT}$  (see below)  $\leq 0,4$  or for  $\frac{M_{Ed}}{M_{cr}} \leq 0,16$ .

For all other classes of member, the resistance to lateral torsional buckling should be determined from:

$$M_{b,Rd} = \chi_{LT} W_y f_y / \gamma_{M1} \quad (5.8)$$

where:

$W_y = W_{pl,y}$  for Class 1 or 2 cross-sections

$W_y = W_{el,y}$  for Class 3 cross-sections

$W_y = W_{eff,y}$  for Class 4 cross-sections

$\chi_{LT}$  is a reduction factor accounting for lateral torsional buckling, given by:

$$\chi_{LT} = \frac{1}{\phi_{LT} + [\phi_{LT}^2 - \bar{\lambda}_{LT}^2]^{0.5}} \leq 1 \quad (5.9)$$

in which:

$$\phi_{LT} = 0,5 \left( 1 + \alpha_{LT} (\bar{\lambda}_{LT} - 0,4) + \bar{\lambda}_{LT}^2 \right) \quad (5.10)$$

$$\bar{\lambda}_{LT} = \sqrt{\frac{W_y f_y}{M_{cr}}} \quad (5.11)$$

$\alpha_{LT}$  is the imperfection factor

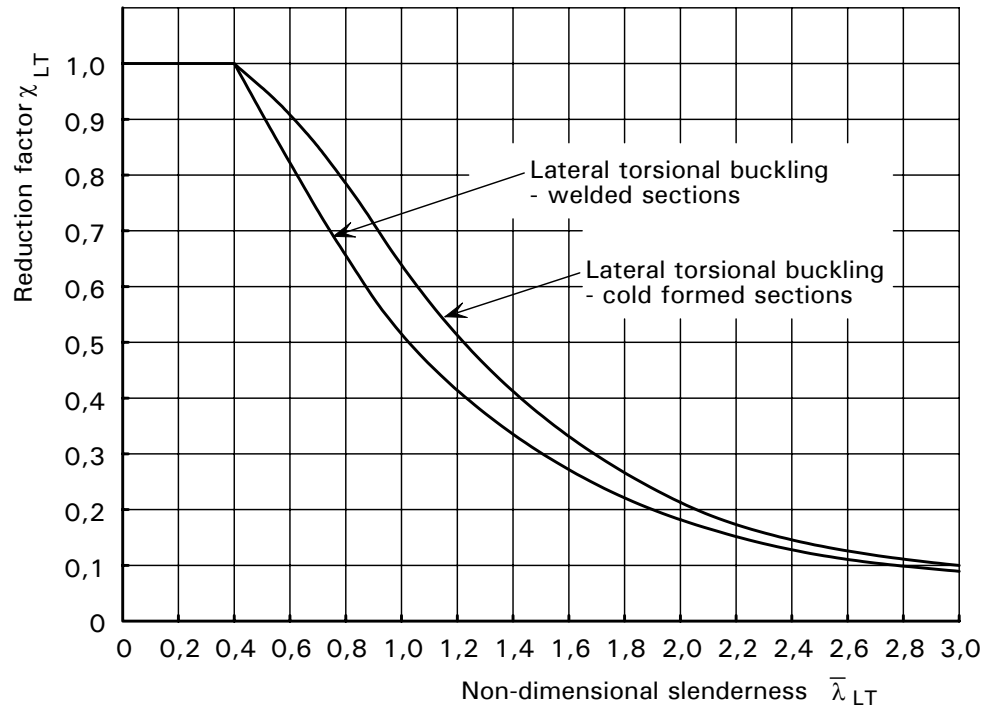
= 0,34 for cold formed sections and hollow sections (welded and seamless)

= 0,76 for welded open sections and other sections for which no test data is available.

$M_{cr}$  is the elastic critical moment for lateral torsional buckling (Appendix B).

Note that for angles, the  $y$  and  $z$  axes in the above should be taken as the  $u$  and  $v$  axes respectively.

The buckling curves for lateral torsional buckling are shown in Figure 5.2.



**Figure 5.2** Buckling curves for lateral-torsional buckling

### 5.4.3 Shear resistance

The shear resistance is limited by either the plastic shear resistance (see Section 4.7.5) or the shear buckling resistance.

The shear buckling resistance only requires checking when  $h_w/t \geq 52\varepsilon/\eta$  for an unstiffened web or  $h_w/t \geq 23\varepsilon\sqrt{k_\tau}/\eta$  for a stiffened web.

The shear buckling resistance for a beam should be obtained from:

$$V_{b,Rd} = V_{bw,Rd} + V_{bf,Rd} \leq \frac{\eta f_{yw} h_w t}{\sqrt{3} \gamma_{M1}} \quad (5.12a)$$

in which the contribution from the web is given by:

$$V_{bw,Rd} = \frac{\chi_w f_{yw} h_w t}{\sqrt{3} \gamma_{M1}} \quad (5.12b)$$

where:

$h_w$  is the clear web depth between flanges (Figure 5.3)

$\varepsilon$  is defined in Table 4.2

$k_\tau$  is the shear buckling coefficient

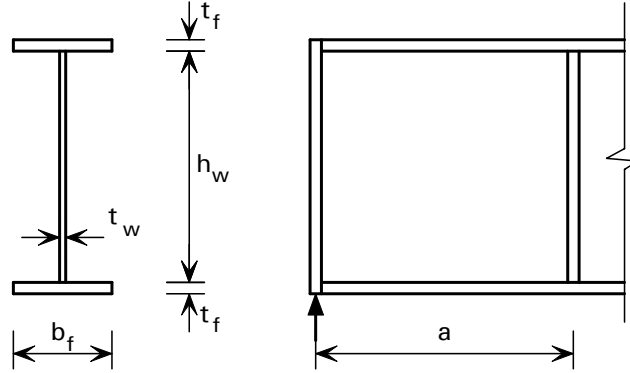
$V_{bw,Rd}$  is the contribution to the shear buckling resistance from the web

$V_{bf,Rd}$  is the contribution to the shear buckling resistance from the flanges

$f_{yw}$  is the characteristic yield strength of web

$\eta$  see EN 1993-1-5 (EN 1993-1-4 recommends  $\eta = 1,20$ .)

Note: The same value of  $\eta$  should be used for calculating the plastic shear resistance as is used for calculating the shear buckling resistance.



**Figure 5.3** Notation for geometrical dimensions

For webs with transverse stiffeners at supports only, and for webs with either intermediate transverse and/or longitudinal stiffeners, the contribution of the web to  $\chi_w$  is given by:

$$\chi_w = \eta \quad \text{for } \bar{\lambda}_w \leq 0,60/\eta \quad (5.13a)$$

$$\chi_w = 0,11 + \frac{0,64}{\bar{\lambda}_w} - \frac{0,05}{\bar{\lambda}_w^2} \quad \text{for } \bar{\lambda}_w > 0,60/\eta \quad (5.13b)$$

For webs with transverse stiffeners at the supports only, the non-dimensional slenderness parameter  $\bar{\lambda}_w$  should be taken as:

$$\bar{\lambda}_w = \left( \frac{h_w}{86,4 t_w \varepsilon} \right) \quad (5.14)$$

For webs with transverse stiffeners at the supports and intermediate transverse and/or longitudinal stiffeners,  $\bar{\lambda}_w$  should be taken as:

$$\bar{\lambda}_w = \left( \frac{h_w}{37,4 t_w \varepsilon \sqrt{k_\tau}} \right) \quad (5.15)$$

in which  $k_\tau$  is the minimum shear buckling coefficient for the web panel. For webs with rigid transverse stiffeners and without longitudinal stiffeners or with more than two longitudinal stiffeners,  $k_\tau$  can be obtained as follows:

$$k_\tau = 5,34 + 4,00(h_w/a)^2 + k_{\tau st} \quad \text{when } a/h_w \geq 1 \quad (5.16a)$$

$$k_\tau = 4,00 + 5,34(h_w/a)^2 + k_{\tau st} \quad \text{when } a/h_w < 1 \quad (5.16b)$$

where:

$$k_{\tau st} = 9(h_w/a)^2 \sqrt[4]{\left( \frac{I_{sl}}{t^3 h_w} \right)^3} \quad \text{but not less than } \frac{2,1}{t} \sqrt[3]{\frac{I_{sl}}{h_w}}$$

where:

$a$  is the distance between centrelines of transverse stiffeners, see Figure 5.3.

$I_{sl}$  is the second moment of area of the longitudinal stiffener about the z-axis.

Equation 5.16 also applies to plates with one or two longitudinal stiffeners, if the aspect ratio  $a/h_w \geq 3$ . For plates with one or two longitudinal stiffeners and an aspect ratio  $a/h_w < 3$ , reference should be made to EN 1993-1-5 Annex A3.

For simplicity, the contribution from the flanges  $\chi_f$  may be neglected. However, if the flange resistance is not completely utilized in withstanding the bending moment ( $M_{Ed} < M_{f,Rd}$ ) then the contribution from the flanges may be obtained as follows:

$$V_{bf,Rd} = \frac{b_f t_f^2 f_{yf}}{c \gamma_{M1}} \left[ 1 - \left[ \frac{M_{Ed}}{M_{f,Rd}} \right]^2 \right] \quad (5.17)$$

where:

$b_f$  and  $t_f$  are taken for the flange which provides the least axial resistance,  $b_f$  being taken as not larger than  $15\epsilon t_f$  on each side of the web

$M_{f,Rd}$  is the moment of resistance of the cross section consisting of the area of the effective flanges only

$$M_{f,Rd} = \frac{M_{f,k}}{\gamma_{M0}}$$

$$c = a \left( 0,17 + \frac{3,5 b_f t_f^2 f_{yf}}{t_w h_w^2 f_{yw}} \right) \text{ and } \frac{c}{a} \leq 0,65$$

$f_{yf}$  is the characteristic yield strength of the flange.

If an axial force  $N_{Ed}$  is also applied, the value of  $M_{f,Rd}$  should be reduced by a factor:

$$\left[ 1 - \frac{N_{Ed}}{\frac{(A_{f1} + A_{f2}) f_{yf}}{\gamma_{M0}}} \right] \quad (5.18)$$

where  $A_{f1}$  and  $A_{f2}$  are the areas of the top and bottom flanges, respectively.

The verification should be performed as follows:

$$\eta_3 = \frac{V_{Ed}}{V_{b,Rd}} \leq 1,0 \quad (5.19)$$

where:

$V_{Ed}$  is the design shear force including shear from torque.

Member verification for biaxial bending and axial compression should be performed as follows:

$$\eta_1 = \frac{N_{Ed}}{f_y A_{eff} / \gamma_{M0}} + \frac{M_{y,Ed} + N_{Ed} e_{y,N}}{f_y W_{y,eff} / \gamma_{M0}} + \frac{M_{z,Ed} + N_{Ed} e_{z,N}}{f_y W_{z,eff} / \gamma_{M0}} \leq 1,0 \quad (5.20)$$

where:

$A_{eff}$  is the effective cross-section area (Section 4.4.1)

$e_{y,N}$  is the shift in the position of the neutral axis with respect to the y axis (Section 4.4.1)

$e_{z,N}$  is the shift in the position of the neutral axis with respect to the z axis (Section 4.4.1)

$M_{y,Ed}$  is the design bending moment with respect to the y axis

$M_{z,Ed}$  is the design bending moment with respect to the z axis

$N_{Ed}$  is the design axial force

$W_{y,eff}$  is the effective section modulus with respect to the y axis (Section 4.4.1)

$W_{z,eff}$  is the effective section modulus with respect to the z axis (Section 4.4.1).

Action effects  $M_{Ed}$  and  $N_{Ed}$  should include global second order effects where relevant. The plate buckling verification of the panel should be carried out for the stress resultants at a distance  $0,4a$  or  $0,5b$ , whichever is the smallest, from the panel end where the stresses are the greater.

Provided that  $\bar{\eta}_3$  (see below) does not exceed 0,5, the design resistance to bending moment and axial force need not be reduced to allow for the shear force. If  $\bar{\eta}_3$  is more than 0,5 the combined effects of bending and shear in the web of an I or box girder should satisfy:

$$\bar{\eta}_1 + \left(1 - \frac{M_{f,Rd}}{M_{pl,Rd}}\right) (2\bar{\eta}_3 - 1)^2 \leq 1,0 \quad \text{for} \quad \bar{\eta}_1 \geq \frac{M_{f,Rd}}{M_{pl,Rd}} \quad (5.21)$$

where:

$M_{f,Rd}$  is the design plastic moment of resistance of the section consisting of the effective area of the flanges

$M_{pl,Rd}$  is the design plastic moment of resistance of the cross section consisting of the effective area of the flanges and the fully effective web irrespective of its section class.

$$\bar{\eta}_1 = \frac{M_{Ed}}{M_{pl,Rd}} \quad (5.22)$$

$$\bar{\eta}_3 = \frac{V_{Ed}}{V_{bw,Rd}} \quad (5.23)$$

Stresses are taken as positive.  $M_{Ed}$  and  $V_{Ed}$  should include second order effects where relevant.

The criterion given in Equation 5.21 should be verified at all sections other than those located at a distance less than  $h_w/2$  from a support with vertical stiffeners.

If an axial force  $N_{Ed}$  is present, then  $M_{pl,Rd}$  should be replaced by the reduced plastic resistance moment  $M_{N,Rd}$  according to 6.2.9 of EN 1993-1-1 and  $M_{f,Rd}$  should be reduced according to Equation 5.18. Reference should be made to EN 1993-1-5 if the axial force is so large that the whole web is in compression.

#### 5.4.4 Web crushing, crippling and buckling

Provided that the flanges are laterally restrained, the resistance of an unstiffened web to forces from concentrated loads or support reactions will be governed by one of three possible failure modes:

- crushing of the web close to the flange, accompanied by plastic deformation of the flange
- crippling of the web in the form of localised buckling and crushing of the web close to the flange, accompanied by plastic deformation of the flange
- buckling of the web over most of the depth of the member.

For cold formed structural sections, the guidance in EN 1993-1-3 for carbon steel can be adopted.

For rolled beams and welded girders, the following approach should be adopted, based on the guidance in EN 1993-1-5.

For unstiffened or stiffened webs the design resistance to local buckling under transverse forces should be taken as:

$$F_{Rd} = f_{yw} L_{eff} t_w / \gamma_{M1} \quad (5.24)$$

where:

$t_w$  is the thickness of the web

$f_{yw}$  is the yield strength of the web

$L_{eff}$  is the effective length for resistance to transverse forces, which should be determined from

$$L_{eff} = \chi_F l_y$$

where:

$l_y$  is the effective loaded length appropriate to the length of stiff bearing  $s_s$

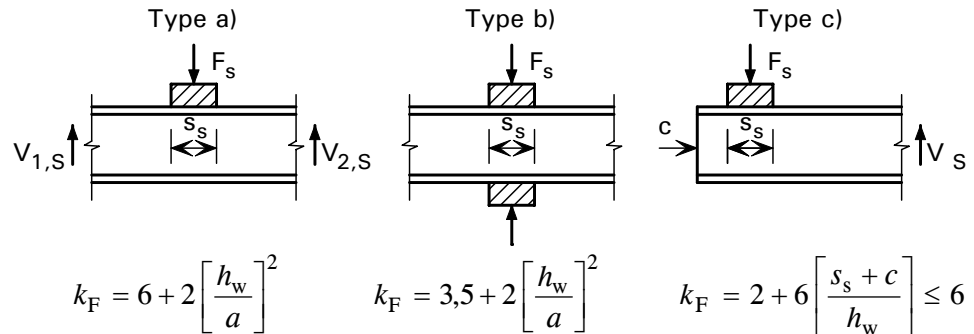
$\chi_F$  is the reduction factor due to local buckling

In addition the effect of the transverse force on the moment resistance of the member should be considered.

To determine  $L_{eff}$ , a distinction should be made between three types of force application, as follows:



- Forces applied through one flange and resisted by shear forces in the web (Figure 5.4a)
- Forces applied to one flange and transferred through the web directly to the other flange (Figure 5.4b)
- Forces applied through one flange close to an unstiffened end (Figure 5.4c)

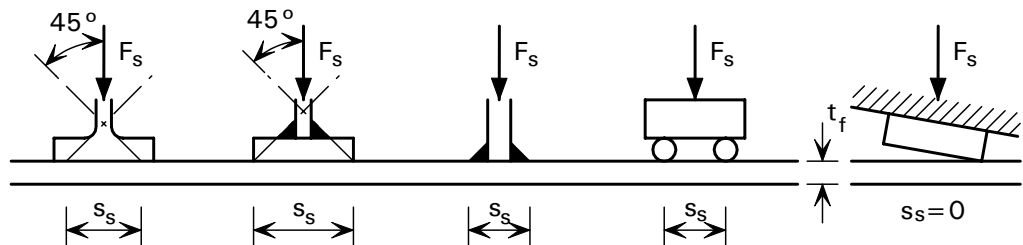


**Figure 5.4** Buckling coefficients for different types of load application

#### **Length of stiff bearing**

The length of stiff bearing,  $s_s$ , on the flange is the distance over which the applied force is effectively distributed and it may be determined by dispersion of load through solid steel material at a slope of 1:1, see Figure 5.5. However,  $s_s$  should not be taken as larger than the depth of the web,  $h_w$ .

If several concentrated loads are closely spaced, the resistance should be checked for each individual load as well as for the total load, with  $s_s$  as the centre-to-centre distance between outer loads.



**Figure 5.5** Length of stiff bearing

#### **Effective loaded length**

The effective loaded length  $l_y$  should be calculated using two dimensionless parameters  $m_1$  and  $m_2$  obtained from:

$$m_1 = \frac{f_{yf} b_f}{f_{yw} t_w} \quad (5.25)$$

$$m_2 = 0,02 \left( \frac{h_w}{t_f} \right)^2 \quad \text{for } \bar{\lambda}_F > 0,5 \quad (5.26a)$$

$$m_2 = 0 \quad \text{for } \bar{\lambda}_F \leq 0,5 \quad (5.26b)$$

For cases a) and b) in Figure 5.4,  $l_y$  should be obtained using

$$l_y = s_s + 2t_f \left(1 + \sqrt{m_1 + m_2}\right) \quad (5.27)$$

but  $l_y$  should not exceed the distance between adjacent transverse stiffeners.

For case c)  $l_y$  should be obtained as the smaller of the values given by Equations 5.28 and 5.29. In Equations 5.30,  $s_s$  should be taken as zero if the structure that introduces the force does not follow the slope of the girder, see Figure 5.5.

$$l_y = l_e + t_f \left[ \sqrt{\frac{m_1}{2} + \left(\frac{l_e}{t_f}\right)^2} + m_2 \right] \quad (5.28)$$

$$l_y = l_e + t_f \sqrt{m_1 + m_2} \quad (5.29)$$

where  $l_e$  is given by:

$$l_e = \frac{k_F E t_w^2}{2 f_{yw} h_w} \leq s_s + c \quad (5.30)$$

#### **Effective length of resistance**

The effective length of resistance should be obtained from:

$$L_{\text{eff}} = \chi_F l_y \quad (5.31)$$

with

$$\chi_F = \frac{0,5}{\bar{\lambda}_F} \leq 1.0 \quad (5.32)$$

$$\bar{\lambda}_F = \sqrt{\frac{l_y t_w f_{yw}}{F_{\text{cr}}}} \quad (5.33)$$

$$F_{\text{cr}} = 0,9 k_F E \frac{t_w^3}{h_w} \quad (5.34)$$

where:

$k_F$  is the buckling coefficient for different types of force application (Figure 5.4).

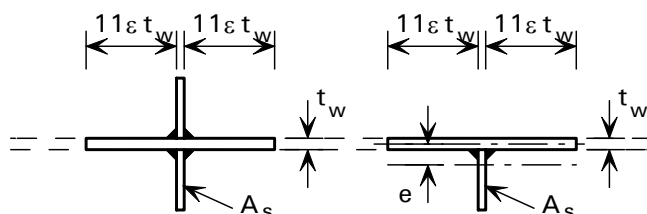
It should be noted that in order to calculate  $m_2$ , a value of  $\bar{\lambda}_F$  needs to be assumed. Once the value of  $\bar{\lambda}_F$  has been calculated, the value of  $m_2$  may need to be recalculated.

#### **5.4.5 Transverse stiffeners**

Transverse stiffeners at supports and at other positions where significant external forces are applied should preferably be double-sided and symmetric about the centreline of the web. These stiffeners should be checked for

cross-section crushing and buckling. Intermediate stiffeners not subject to external forces need only be checked for buckling.

The effective cross-section to use in the buckling check should include a width of web plate as shown in Figure 5.6. At the end of a member (or at the openings in the web) the width of web included in the cross-section should not exceed that available.



**Figure 5.6** *Effective cross-section of stiffeners for buckling*

The out-of-plane buckling resistance  $N_{b,Rd}$  of the stiffener should be determined from Section 5.3.3 using  $\alpha = 0,49$  and  $\bar{\lambda}_0 = 0,2$ . The buckling length  $l$  of the stiffener should be appropriate for the conditions of restraint, but not less than  $0,75h_w$ , where both ends are fixed laterally. A larger value of  $l$  should be used for conditions that provide less end restraint. The torsional buckling resistance of the cruciform section should also be checked.

For single-sided or other asymmetric stiffeners the resulting eccentricity should be allowed for in accordance with Section 5.5.2.

At supports or at intermediate positions where significant loads are applied, the buckling resistance should exceed the reaction or load. At other intermediate positions, the compression force  $N_{Ed}$  in the stiffener may be obtained from:

$$N_{Ed} = V_{Ed} - \frac{1}{\bar{\lambda}_w^2} \frac{f_{yw} h_w t_w}{\sqrt{3} \gamma_{M1}} \quad (5.35)$$

where:

$V_{Ed}$  is the design shear force in the member.

The above expression should be calculated assuming the stiffener under consideration is removed.

The second moment of area of an intermediate stiffener,  $I_s$ , should satisfy the following:

$$a / h_w < \sqrt{2}, \quad I_{st} \geq 1,5 h_w^3 t^3 / a^2 \quad (5.36)$$

$$a / h_w \geq \sqrt{2}, \quad I_{st} \geq 0,75 h_w^3 t^3 \quad (5.37)$$

#### 5.4.6 Determination of deflections

Deflections should be determined for the load combination at the relevant Serviceability Limit State.

The deflection of elastic beams (i.e. those not containing a plastic hinge) may be estimated by standard structural theory, except that the secant modulus of elasticity should be used instead of Young's modulus. The secant modulus

varies with the stress level in the beam and values may be found in Appendix C. This is a simplified method which is accurate for predicting deflections when the secant modulus is based on the maximum stress in the member and this maximum stress does not exceed 65% of the 0,2% proof strength. At higher levels of stress, the method becomes very conservative and a more accurate method (e.g. one which involves integrating along the length of the member) should be used.

In the case of Class 4 cross-sections and/or members subject to shear lag, an effective section should be used in the calculations. As a first estimate, it is appropriate to use the effective section based on the effective widths established in Sections 4.4.1 and/or 4.4.2. As a refinement, it is possible to use an effective section based on the effective buckling widths determined for the actual stress in the elements by taking  $\varepsilon$  in Section 4.4.1 (but not in Section 4.4.2) as:

$$\varepsilon = \left[ \frac{235}{\sigma} \frac{E}{210000} \right]^{1/2} \quad (5.38)$$

where:

- $\sigma$  is the actual stress in the element in the associated effective cross-section
- $E$  is Young's modulus.

## 5.5 Members subject to combinations of axial load and bending moments

### 5.5.1 Axial tension and bending

Tension members with moments should be checked for resistance to lateral torsional buckling in accordance with Section 5.4.2 under the moment alone. They should also be checked for capacity under the combined effects of axial load and moment at the points of maximum bending moment and axial load. The following relationship should be satisfied:

$$\frac{N_{Ed}}{N_{Rd}} + \frac{M_{y,Ed}}{M_{y,Rd}} + \frac{M_{z,Ed}}{M_{z,Rd}} \leq 1 \quad (5.39)$$

where:

- $N_{Ed}$  is the design axial tensile load in the member at the critical location
- $N_{Rd}$  is the design resistance of the member in tension
- $M_{y,Ed}$  is the design moment about the major axis at the critical section
- $M_{z,Ed}$  is the design moment about the minor axis at the critical section
- $M_{y,Rd}$  is the design moment resistance about the major axis in the absence of axial load and include any reduction that may be caused by shear effects (Section 4.7.4)
- $M_{z,Rd}$  is the design moment about the minor axis in the absence of axial load and includes any reduction that may be caused by shear effects (Section 4.7.4).

### 5.5.2 Axial compression and bending

In addition to satisfying the requirements of cross-sectional resistance (see Section 4.7.6) at every point along the length of the member and the general requirements for beam members (see Section 5.4), interaction effects should be considered between compressive loads and bending moments.

#### ***Axial compression and uniaxial major axis moment:***

To prevent premature buckling about the major axis:

$$\frac{N_{Ed}}{(N_{b,Rd})_{\min}} + k_y \left( \frac{M_{y,Ed} + N_{Ed} e_{Ny}}{\beta_{W,y} W_{pl,y} f_y / \gamma_{M1}} \right) \leq 1 \quad (5.40)$$

To prevent premature buckling about the minor axis (for members subject to lateral-torsional buckling):

$$\frac{N_{Ed}}{(N_{b,Rd})_{\min 1}} + k_{LT} \left( \frac{M_{y,Ed} + N_{Ed} e_{Ny}}{M_{b,Rd}} \right) \leq 1 \quad (5.41)$$

#### ***Axial compression and uniaxial minor axis moment:***

To prevent premature buckling about the minor axis:

$$\frac{N_{Ed}}{(N_{b,Rd})_{\min}} + k_z \left( \frac{M_{z,Ed} + N_{Ed} e_{Nz}}{\beta_{W,z} W_{pl,z} f_y / \gamma_{M1}} \right) \leq 1 \quad (5.42)$$

#### ***Axial compression and biaxial moments:***

All members should satisfy:

$$\frac{N_{Ed}}{(N_{b,Rd})_{\min}} + k_y \left( \frac{M_{y,Ed} + N_{Ed} e_{Ny}}{\beta_{W,y} W_{pl,y} f_y / \gamma_{M1}} \right) + k_z \left( \frac{M_{z,Ed} + N_{Ed} e_{Nz}}{\beta_{W,z} W_{pl,z} f_y / \gamma_{M1}} \right) \leq 1 \quad (5.43)$$

Members potentially subject to lateral-torsional buckling should also satisfy:

$$\frac{N_{Ed}}{(N_{b,Rd})_{\min 1}} + k_{LT} \left( \frac{M_{y,Ed} + N_{Ed} e_{Ny}}{M_{b,Rd}} \right) + k_z \left( \frac{M_{z,Ed} + N_{Ed} e_{Nz}}{\beta_{W,z} W_{pl,z} f_y / \gamma_{M1}} \right) \leq 1 \quad (5.44)$$

In the above expressions:

$e_{Ny}$  and  $e_{Nz}$  are the shifts in the neutral axes when the cross-section is subject to uniform compression

$N_{Ed}$ ,  $M_{y,Ed}$  and  $M_{z,Ed}$  are the design values of the compression force and the maximum moments about the y-y and z-z axis along the member, respectively

$(N_{b,Rd})_{\min}$  is the smallest value of  $N_{b,Rd}$  for the following four buckling modes: flexural buckling about the y axis, flexural buckling about the z axis, torsional buckling and torsional-flexural buckling (see Sections 5.3.3. and 5.3.4)

$(N_{b,Rd})_{\min 1}$  is the smallest value of  $N_{b,Rd}$  for the following three buckling modes: flexural buckling about the z axis, torsional buckling and torsional-flexural buckling (see Sections 5.3.3. and 5.3.4)

$\beta_{w,y}$  and  $\beta_{w,z}$  are the values of  $\beta_w$  determined for the y and z axes respectively in which

$$\begin{aligned}\beta_w &= 1 && \text{for Class 1 or 2 cross-sections} \\ &= W_{el}/W_{pl} && \text{for Class 3 cross-sections} \\ &= W_{eff}/W_{pl} && \text{for Class 4 cross-sections}\end{aligned}$$

$W_{pl,y}$  and  $W_{pl,z}$  are the plastic moduli for the y and z axes respectively

$M_{b,Rd}$  is the lateral-torsional buckling resistance (see Section 5.4.2)

$k_y$ ,  $k_z$ ,  $k_{LT}$  are the interaction factors

$$k_y = 1,0 + 2(\bar{\lambda}_y - 0,5) \frac{N_{Ed}}{N_{b,Rd,y}} \quad \text{but} \quad 1,2 \leq k_y \leq 1,2 + 2 \frac{N_{Ed}}{N_{b,Rd,y}}$$

$$k_z = 1,0 + 2(\bar{\lambda}_z - 0,5) \frac{N_{Ed}}{(N_{b,Rd})_{\min 1}} \quad \text{but} \quad 1,2 \leq k_z \leq 1,2 + 2 \frac{N_{Ed}}{(N_{b,Rd})_{\min 1}}$$

$$k_{LT} = 1,0$$

Note that the National Annexes may give other interaction formulae as alternatives to the above equations.

Note that for angles, the y and z axes in the above should be taken as the u and v axes respectively.

## 6 JOINT DESIGN

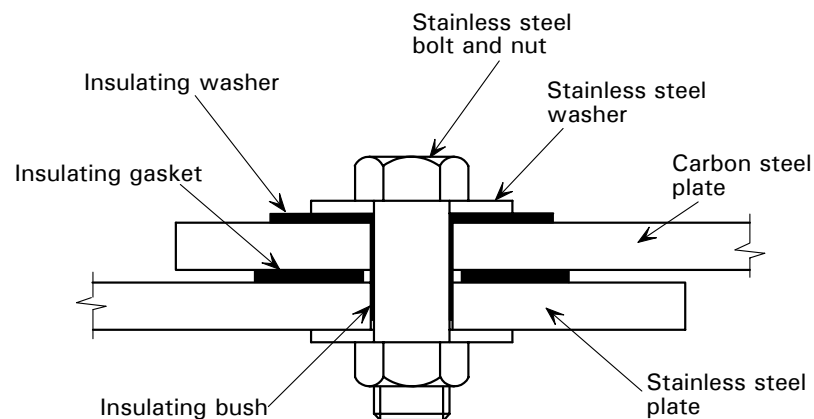
### 6.1 General recommendations

#### 6.1.1 Durability

The design of joints, in particular, needs the most careful attention to maintain optimum corrosion resistance.

This is especially so for joints that may become wet from either the weather, spray, immersion, or condensation, etc. The possibility of avoiding or reducing associated corrosion problems by locating joints away from the source of dampness should be investigated. Alternatively, it may be possible to remove the source of dampness; for instance, in the case of condensation, by adequate ventilation or by ensuring that the ambient temperature within the structure lies above the dew point temperature.

Where it is not possible to prevent a joint involving carbon steel and stainless steel from becoming wet, consideration should be given to preventing bimetallic corrosion, see Section 3.7.2. The use of carbon steel bolts with stainless steel structural elements should always be avoided. In bolted joints that would be prone to an unacceptable degree of corrosion, provision should be made to isolate electrically the carbon steel and stainless steel elements. This entails the use of insulating washers and possibly bushes; typical suitable details are shown in Figure 6.1. For offshore structures, it will be found that certifying authorities may require such measures and the designer is strongly urged to liaise with the designated authority at an early stage to establish exact requirements.



**Figure 6.1** Typical detail for connecting dissimilar materials (to avoid bimetallic corrosion)

With respect to welded joints involving carbon and stainless steels, it is generally recommended that any paint system applied to the carbon steel should extend over the weldment and cover some area of the stainless steel.

Care should be taken in selecting appropriate materials for the environment to avoid crevice corrosion in bolted joints (see Section 3.7.2).

The heating and cooling cycle involved in welding affects the microstructure of all stainless steels, though some grades more than others, and this is of

particular importance for duplex materials. It is essential that suitable welding procedures and consumables are used and that qualified welders undertake the work. Guidance on this matter is given in Section 10.4.

### **6.1.2 Design assumptions**

Joints may be designed by distributing the internal forces and moments in a realistic manner, bearing in mind the relative stiffness of elements that make up the joint. The internal forces and moments must be in equilibrium with the applied forces and moments. Each element participating in the assumed load paths should be capable of resisting the forces assumed in the analysis and at the implied deformation within the element's deformation capacity.

### **6.1.3 Intersections and splices**

Members meeting at a joint should normally be arranged with their centroidal axes intersecting at a point. Where there is eccentricity at intersections, the members and connections should be designed to accommodate the resulting moments. In the case of joints with angles or tees connected by at least two bolts at each joint, the setting out lines for the bolts in the angles and tees may be substituted for the centroidal axes for the purpose of determining the intersection at the joints.

Splices in beams should preferably be located as near as possible to points of contraflexure (zero bending moment). In column splices, consideration should be given to moments caused by  $P-\delta$  effects.

### **6.1.4 Other general considerations**

Where a joint is subject to impact, vibration, or frequent reversal of significant stress, welding is the preferred method of joining. These connections should be checked for the effects of fatigue (see Section 8).

Ease of fabrication and erection are factors to be considered in the design of all joints and splices. Attention should be paid to:

- use of standardised details
- the clearances necessary for safe erection
- the clearances needed for tightening fasteners
- the need for access for welding
- the requirements of welding procedures
- the effects of angular and length tolerances on fit-up.

It should be noted that greater welding distortions will be associated with the austenitic stainless steels than with carbon steels (see Section 10.4.4). Attention should also be paid to the requirements for subsequent inspection and maintenance.



## 6.2 Bolted connections

### 6.2.1 General

The recommendations in this Section apply to connections with bolts in clearance holes where shear, tension or a combination of shear and tension is to be carried. It is good practice to provide washers under both the bolt head and the nut. Guidance on appropriate materials for bolts and nuts is given in Sections 3.1.2 and 10.5.

Shear forces are transferred by bearing between the bolts and the connected parts. No recommendations are given for connections in which shear is transferred by frictional resistance, but see Section 6.2.2.

The strength of a connection is to be taken as the lesser of the strength of the connected parts (see Section 6.2.3) and that of the fasteners (see Section 6.2.4).

To restrict irreversible deformation in bolted connections, the stresses in bolts and net cross-sections at bolt holes under the characteristic load combinations should be limited to the yield strength.

### 6.2.2 Preloaded bolts

Stainless steel bolts may be used as preloaded bolts provided appropriate tensioning techniques are used. If stainless steel bolts are highly torqued, galling can be a problem. When preload is applied, consideration should be given to time-dependent stress relaxation. Connections should not be designed as slip resistant at either the serviceability or ultimate limit state unless acceptability in the particular application can be demonstrated by test.

### 6.2.3 Connected parts

#### *Holes*

Holes can be formed by drilling or punching. However, the cold working associated with punching may increase the susceptibility to corrosion and therefore punched holes are less suitable in aggressive environments (e.g. heavy industrial and marine environments).

The maximum clearances in standard holes are:

1 mm for M12 and M14 bolts (M14 is non standard size)

2 mm for M16 to M24 bolts

3 mm for M27 and larger bolts

#### *Position of holes*

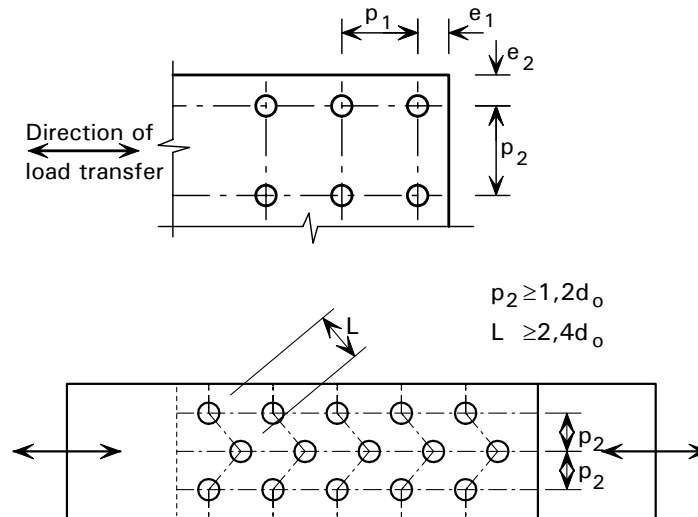
Edge distance is defined as the distance from the centre of a hole to the adjacent edge of the connecting part at right angles to the direction of stress; end distance is similarly defined but in the direction in which the fastener bears.

The minimum value of the end distance,  $e_1$ , or that of the edge distance,  $e_2$ , (see Figure 6.2) should be taken as  $1,2d_0$ , where  $d_0$  is the diameter of the bolt hole. Note that the end distance may need to be larger than this to provide adequate bearing resistance, see below.

The maximum value of the end or edge distance should be restricted to  $4t + 40$  mm, where  $t$  is the thickness (in mm) of the thinner outer ply.

The minimum centre-to-centre bolt spacing is  $2,2d_0$  in the direction of stress,  $p_1$ , (see Figure 6.2). The corresponding minimum spacing,  $p_2$ , normal to the direction of stress is  $2,4d_0$ .

The maximum spacing of bolts in any direction should be such that local compressive buckling of the plies is taken into account, see EN 1993-1-8.



**Figure 6.2** Symbols for defining position of holes

For staggered bolt rows, a minimum line spacing  $p_2=1,2d_0$  may be used if the minimum distance,  $L$ , between any two fasteners in a staggered row is greater or equal to  $2,4d_0$ , see Figure 6.2.

### **Bearing resistance**

The appropriate resistance of a bolted connection in stainless steel will usually be governed by serviceability criteria in which the hole elongation at serviceability loads is to be limited. In order to avoid carrying out a separate check for serviceability, a limit on hole elongation at ultimate load is placed by using a reduced value of the ultimate tensile strength  $f_{u,red}$  where:

$$f_{u,red} = 0.5f_y + 0.6f_u \text{ but } \leq f_u \quad (6.1)$$

The value of  $F_{b,Rd}$  is given by:

$$F_{b,Rd} = \frac{k_1 \alpha_b f_{u,red} d t}{\gamma_{M2}} \quad (6.2)$$

where  $\alpha_b$  is the smallest of:

- $\alpha_d$
- $f_{ub} / f_{u,red}$
- 1.0

where:

- $d$  is the bolt diameter
- $t$  is the ply thickness

$f_{ub}$  is the characteristic ultimate tensile strength of the connected ply (taken as the minimum specified ultimate tensile strength, see Table 3.1).

$\alpha_d = e_1 / 3d_0$  for end bolts in the direction of load transfer

$\alpha_d = \frac{p_1}{3d_0} - \frac{1}{4}$  for inner bolts in the direction of load transfer

$k_1$  is the smaller of  $2,8 \frac{e_2}{d_o} - 1,7$  or 2,5 for edge bolts perpendicular to the direction of load transfer

$k_1$  is the smaller of  $1,4 \frac{p_2}{d_o} - 1,7$  or 2,5 for inner bolts perpendicular to the direction of load transfer

In the case of single lap joints of flats with only one bolt row, the bolts should be provided with washers under both the head and the nut and the bearing resistance for each bolt should be further limited to:

$$F_{b,Rd} = \frac{1,5 f_{u,red} d t}{\gamma_{M2}} \quad (6.3)$$

The resistance of a group of fasteners may be determined as the sum of the bearing resistances  $F_{b,Rd}$  of the individual fasteners provided that the design shear resistance  $F_{v,Rd}$  of each individual fastener is greater or equal to the design bearing resistance  $F_{b,Rd}$ . Otherwise the resistance of a group of fasteners should be determined by using the smallest resistance of the individual fasteners multiplied by the number of fasteners.

### **Tension resistance**

The tensile resistance of the connected part should be based on the lesser of:

a) the plastic resistance of the gross cross-section

$$N_{pl,Rd} = \frac{A f_y}{\gamma_{M0}} \quad (6.4)$$

b) the ultimate resistance of the net cross-section at holes for fasteners

$$N_{u,Rd} = \frac{k_r A_{net} f_u}{\gamma_{M2}} \quad (6.5)$$

where the terms are defined in Section 4.7.2.

Note that the equation for the ultimate resistance of the net section should only be used for one shear plane when washers are present under both the head and nut of the bolt.

If ductile behaviour is required, then the plastic resistance of the gross section must be less than the net section ultimate resistance. Requirements for ductility

and rotation capacity are given in EN 1993-1-8. Requirements for seismic design are given in EN 1998.

### **Design for block tearing**

The guidance in EN 1993-1-8 is applicable.

### **Angles connected by one leg and other unsymmetrically connected members in tension**

The eccentricity of fasteners in end connections and the effects of the spacing and edge distances of the bolts should be taken into account in determining the design resistance of unsymmetrical members, as well as of symmetrical members that are connected unsymmetrically, such as angles connected by one leg.

Angles connected by a single row of bolts in one leg may be treated as concentrically loaded and the design ultimate resistance of the net section determined as follows:

$$\text{With 1 bolt: } N_{u,Rd} = \frac{2,0 (e_2 - 0,5d_0) t f_u}{\gamma_{M2}} \quad (6.6)$$

$$\text{With 2 bolts: } N_{u,Rd} = \frac{\beta_2 A_{net} f_u}{\gamma_{M2}} \quad (6.7)$$

$$\text{With three or more bolts: } N_{u,Rd} = \frac{\beta_3 A_{net} f_u}{\gamma_{M2}} \quad (6.8)$$

where:

$\beta_2$  and  $\beta_3$  are reduction factors dependent on the pitch  $p_1$  as given in Table 6.1. For intermediate values of  $p_1$  the value of  $\beta$  can be determined by linear interpolation.

$A_{net}$  is the net area of the angle. For an unequal-leg angle connected by its smaller leg  $A_{net}$  should be taken as equal to the net section area of an equivalent equal-leg angle of leg size equal to that of the smaller leg.

**Table 6.1** Reduction factors  $\beta_2$  and  $\beta_3$

Connection	Factor	Pitch, $p_1$	
		$\leq 2,5d_0$	$\geq 5,0d_0$
2 bolts	$\beta_2$	0,4	0,7
3 bolts or more	$\beta_3$	0,5	0,7

## **6.2.4 Fasteners**

### **Net areas**

The area of the bolt to be used in calculations for bolts in tension should be taken as the tensile stress area, as defined in the appropriate product standard.

For bolts in shear, the greater shank area may be used if it can be guaranteed that the threaded portion will be excluded from the shear plane; consideration should be given to the possibility that bolts may be inserted from either

direction. If no such guarantee can be given, the tensile stress area should be used.

### **Shear resistance**

The shear resistance of a bolted connection is dependent on the number of shear planes and their position along the bolt. For each shear plane, the shear resistance in the absence of tension may be determined as follows:

$$F_{v,Rd} = \frac{\alpha f_{ub} A}{\gamma_{M2}} \quad (6.9)$$

where:

$A$  is the gross cross-section area of the bolt (if the shear plane passes through unthreaded portion of the bolt); or the tensile stress area of the bolt (if the shear plane passes through the threaded portion of the bolt)

$f_{ub}$  is the ultimate tensile strength of the bolt.

The value of  $\alpha$  may be defined in the National Annex. The recommended values are:

- if the shear plane passes through the unthreaded portion of the bolt,  $\alpha = 0,6$
- if the shear plane passes through the threaded portion of the bolt,  $\alpha = 0,5$ .

### **Tensile resistance**

The tension resistance of a bolt is given by  $F_{t,Rd}$ :

$$F_{t,Rd} = \frac{k_2 f_{ub} A_s}{\gamma_{M2}} \quad (6.10)$$

where:

$k_2 = 0,63$  for countersunk bolts, otherwise  $k_2 = 0,9$ .

Where fasteners are required to carry an applied tensile force, they should be proportioned to resist the additional force due to prying action, where this can occur. Guidance on accounting for prying forces is given in EN 1993-1-8.

### **Combined shear and tension**

When a bolt is simultaneously subjected to a shear force,  $F_{v,Ed}$ , and a tensile force (including prying effects),  $F_{t,Ed}$ , interaction effects should be considered. This may be accounted for by satisfying the following interaction relationship:

$$\frac{F_{v,Ed}}{F_{v,Rd}} + \frac{F_{t,Ed}}{1,4 F_{t,Rd}} \leq 1,0 \quad (6.11)$$

where  $F_{v,Rd}$  and  $F_{t,Rd}$  are as given above. Note that the design tensile force (including any force due to prying action) must also be less than the tensile resistance.

### ***Long joints and large grip lengths***

For splices of unusual length (say 500 mm or 15 bolt diameters upwards) or when the grip length (i.e. the total thickness of the connected plies) exceeds 5 bolt diameters, the shear resistance should be reduced. In the absence of data for stainless steel, it is recommended to consult carbon steel rules for these situations in EN 1993-1-8.

## **6.3 Mechanical fasteners for thin gauge material**

The design of connections for stainless steel sheets using self-tapping screws can be calculated in accordance with EN 1993-1-3, except that the pull-out strength should be determined by testing. In order to avoid seizure of the screw or stripping its thread, the ability of the screw to drill and form threads in stainless steel should be demonstrated by tests unless sufficient experience is available. The reduced value for the tensile strength,  $f_{u,red}$ , given in Equation 6.1, should be used in place of  $f_u$ .

## **6.4 Welded connections**

### **6.4.1 General**

It is essential that welds are made using correct procedures, including compatible consumables, with suitably qualified welders (see Section 10.4). This is important not only to ensure the strength of the weld and to achieve a defined weld profile but also to maintain corrosion resistance of the weld and surrounding material.

The following recommendations apply to full and partial penetration butt welds and to fillet welds made by an arc welding process such as:

Process number	Process name
111	Metal-arc welding with covered electrode (manual metal arc welding)
121	Submerged arc welding with wire electrode
122	Submerged arc welding with strip electrode
131	Metal-arc inert gas welding (MIG welding)
135	Metal-arc active gas welding (MAG welding)
137	Flux-cored wire metal-arc welding with inert gas shield
141	Tungsten inert gas welding (TIG welding)
15	Plasma arc welding

(Process numbers are as defined in EN ISO 4063.)

Compatible consumables should be used, such that the weld yield strength and ultimate strengths exceed those of the parent material. (For undermatched consumables, see Section 6.4.4.) Table 6.2 gives suitable welding consumables for different grades and Table 6.3 gives the mechanical properties of these consumables.

**Table 6.2** *Applicable steel grades and welding consumables*

Base material  Number	Welding consumables		
	Covered electrodes EN 1600	Wires and rods EN 12072	Flux cored electrodes EN 12073
1.4301	E 19 9	G 19 9 L	T 19 9 L
1.4306	E 19 9 L	G 19 9 L	T 19 9 L
1.4307	E 19 9 L	G 19 9 L	T 19 9 L
1.4318	E 19 9 L	G 19 9 L	T 19 9 L
1.4541	E 19 9 Nb	G 19 9 Nb	T 19 9 Nb
1.4401	E 19 12 2	G 19 12 3 L	T 19 12 3 L
1.4404	E 19 12 3 L	G 19 12 3 L	T 19 12 3 L
1.4571	E 19 12 3 Nb	G 19 12 3 Nb	T 19 12 3 Nb
1.4362	E 25 7 2 N L	G 25 7 2 L	T 22 9 3 N L
1.4462	E 25 7 2 N L	G 25 7 2 L	T 22 9 3 N L

**Table 6.3** *Mechanical properties of welding consumables according to EN 1600, EN 12072 and EN 12073*

Weld material	Yield strength N/mm <sup>2</sup>	Ultimate tensile strength N/mm <sup>2</sup>
E 19 9	350	550
E/G/T 19 9 L	320	510
E/G/T 19 9 Nb	350	550
E 19 12 2	350	550
E/G/T 19 12 3 L	320	510
E/G/T 19 12 3 Nb	350	550
E 25 7 2 N L	500	700
G 25 7 2 L	500	700
T 22 9 3 N L	450	550

Note that special consideration should be given to the case when a test value of the 0,2% proof stress is used as a basis of design (i.e. design to Section 3.2.4(ii)). Manufacturers of stainless steel and consumables may help in the selection of appropriate consumables. The weld metal should be at least as noble as the parent material.

Intermittent fillet welds and intermittent partial penetration butt welds are best avoided in all but the mildest of environments, to reduce the possibility of corrosion. Furthermore, intermittent butt welds should be used with care in marine or very heavily polluted onshore environments, particularly where flow induced by surface tension may occur.

#### 6.4.2 Fillet welds

##### **Application**

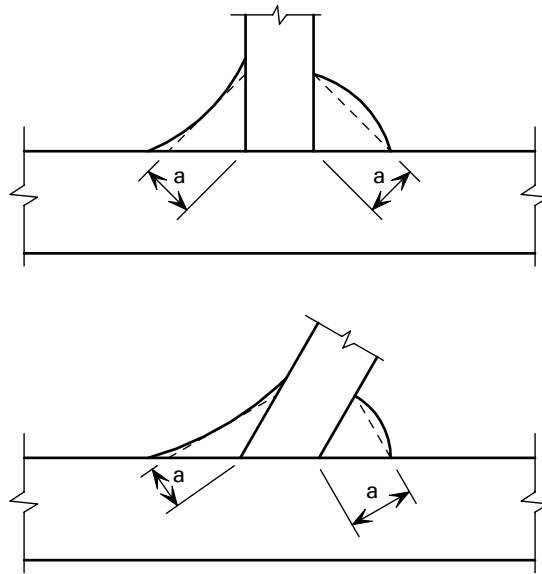
Fillet welds may be used for connecting parts where fusion faces form an angle of between 60° to 120°. For angles smaller than 60°, fillet welds may be used but should be considered as partial penetration butt welds for design purposes. For angles over 120°, fillet welds should not be relied upon to transmit forces.

A fillet weld should not be used in situations which produce a bending moment about the longitudinal axis of the weld if this causes tension at the root of the weld.

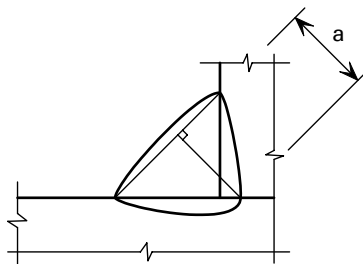
**Effective length and throat size**

The effective length of a fillet weld may be taken as the overall length of the full-size fillet. However, welds with effective lengths shorter than 40 mm or 6 times the throat thickness, should not be relied upon to transmit forces.

The effective throat thickness,  $a$ , of a fillet weld should be taken as the height of the largest triangle (with equal or unequal legs) that can be inscribed within the fusion faces and the weld surface, measured perpendicular to the outer side of this triangle, see Figure 6.3. Advantage may be taken of the additional throat thickness of deep penetration fillet welds, see Figure 6.4, provided that preliminary tests show that the required penetration can consistently be achieved.



**Figure 6.3** *Fillet weld throat thickness*



**Figure 6.4** *Deep penetration fillet weld throat thickness*

**Design stress and design shear strength**

The design stress is obtained as the vector sum of the stresses due to all forces and moments transmitted by the weld. The design stress is calculated for the effective length and throat thickness (see above).

The design resistance of the fillet weld will be sufficient if the following are both satisfied:

$$[\sigma_{\perp}^2 + 3(\tau_{\perp}^2 + \tau_{\parallel}^2)]^{0.5} \leq \frac{f_u}{\beta_w \gamma_{M2}} \tag{6.12a}$$



$$\sigma_{\perp} \leq \frac{0,9f_u}{\gamma_{M2}} \quad (6.12b)$$

where:

- $\sigma_{\perp}$  is the normal stress perpendicular to the throat
- $\tau_{\perp}$  is the shear stress (in the plane of the throat) perpendicular to the axis of the weld
- $\tau_{\parallel}$  is the shear stress (in the plane of the throat) parallel to the axis of the weld
- $f_u$  is the nominal ultimate tensile strength of the weaker part joined
- $\beta_w$  is taken as 1,0 for all nominal strength classes of stainless steel, unless a lower value is justified by tests.

Alternatively, the Simplified method in 4.5.3.3 of EN 1993-1-8 can be used to calculate the design resistance of a fillet weld.

### 6.4.3 Butt welds

#### ***Full penetration butt welds***

The design resistance of a full penetration butt weld should be taken as equal to the design resistance of the weaker of the parts joined, provided that the weld satisfies the recommendations of Section 6.3.1.

#### ***Partial penetration butt welds***

Partial penetration butt welds may be used to transmit shear forces. They are not recommended in situations where they would be subjected to tension.

The resistance of a partial penetration butt weld may be determined as for a deep penetration fillet weld. The throat thickness of a partial penetration butt weld may be taken as the depth of penetration that can be consistently achieved, as determined by procedure trials. In the absence of procedure trials, the throat thickness can be assumed to be the depth of preparation less 3 mm.

### 6.4.4 Welding cold worked stainless steel

The same principles apply to welding cold worked stainless steel as to annealed stainless steel provided that:

- The welded joint is subjected to axial load.
- The cold worked strength level of the stainless steel does not exceed CP500 or C850.
- Welding consumables are chosen according to Table 6.2.
- The resistance of the base material in the heat affected zones is based on the tensile strength of the annealed base material.

The filler metal may have lower strength than the base material. For undermatched electrodes, the design resistance of fillet and butt welds should be based on the ultimate strength of the weld metal (see Table 6.3) with  $\beta_w$  taken as 1.0.

## 7 DESIGN FOR FIRE RESISTANCE

### 7.1 General

This Section deals with the design of stainless steel structures that, for reasons of general fire safety, are required to fulfil certain functions, in terms of avoiding premature collapse of the structure (load bearing function), when exposed to fire. The recommendations are only concerned with passive methods of fire protection and are applicable to stainless steel grades and structures that are generally designed within the rules of Sections 1 to 6 of this document.

Austenitic stainless steels generally retain a higher proportion of their room temperature strength than carbon steels above temperatures of about 550 °C, and a higher proportion of their stiffness at all temperatures.

EN 1991-1-2 gives the thermal and mechanical actions on structures exposed to fire. Fire is designated an accidental design situation in the Eurocodes. EN 1990 gives combinations of actions for accidental design situations, and recommends that the partial factors for actions are taken as 1,0. EN 1993-1-2 recommends that the partial material safety factor  $\gamma_{M,fi}$  for the fire situation should be taken as 1,0.

The performance requirements of a stainless steel structure that may be subjected to accidental fire loading are no different to those of carbon steel, namely:

- Where mechanical resistance in the case of fire is required, the structure should be designed and constructed in such a way that it maintains its load bearing function during the relevant fire exposure.
- Deformation criteria should be applied where the means of fire protection, or the design criteria for separating elements, require the deformation of the load bearing structure to be considered. However, it is not necessary to consider the deformation of the load bearing structure if the fire resistance of the separating elements is based on the standard fire curve.

### 7.2 Mechanical properties at elevated temperatures

Table 7.1 gives strength and stiffness retention factors, relative to the appropriate value at 20 °C, for the stress-strain relationship and the parameter  $g_{2,\theta}$  for grades of stainless steel at elevated temperatures. The factors are defined below:

$k_{0,2proof,\theta}$  0,2% proof strength at temperature  $\theta$  relative to design strength at 20 °C, i.e.  $f_{0,2proof,\theta}/f_y$

$g_{2,\theta}$  a parameter used to calculate  $f_{2,\theta}$ , the strength at 2% total strain at temperature  $\theta$ , using the following expression:

$$f_{2,\theta} = f_{0,2proof,\theta} + g_{2,\theta}(f_{u,\theta} - f_{0,2proof,\theta}) \quad (7.1)$$

$k_{u,\theta}$  ultimate strength at temperature  $\theta$  relative to ultimate strength at 20 °C, i.e.  $f_{u,\theta}/f_u$

$k_{E,\theta}$  slope of linear elastic range at temperature  $\theta$  relative to slope at 20°C, i.e.  $E_\theta/E$

where:

$E$  is Young's modulus at 20°C (= 200 000 N/mm<sup>2</sup>)

$f_y$  is the characteristic yield strength at 20°C, as defined in Section 3.2.4

$f_u$  is the characteristic ultimate tensile strength at 20°C, as defined in Section 3.2.4.

In determining the structural fire resistance of stainless steel members, the following characteristic material strength should be used:

Columns	$f_{0,2\text{proof},\theta}$	(all cross-section Classes)
Restrained beams	$f_{2,\theta}$	(Class 1-3 cross-sections)
	$f_{0,2\text{proof},\theta}$	(Class 4 cross-sections)
Unrestrained beams	$f_{0,2\text{proof},\theta}$	(all cross-section Classes)
Tension members	$f_{2,\theta}$	(all cross-section Classes).

For Class 1-3 restrained beams and tension members, in situations which require consideration of the deformation criteria, the strength at a total strain of 1,0%,  $f_{1,\theta}$  is recommended as a basis for the calculations instead of  $f_{2,\theta}$ . The value of  $f_{1,\theta}$  should be calculated using the following relationship:

$$f_{1,\theta} = f_{0,2\text{proof},\theta} + 0,5g_{2,\theta}(f_{u,\theta} - f_{0,2\text{proof},\theta}) \quad (7.2)$$

Values for  $f_{0,2\text{proof},\theta}$  are given relative to the characteristic yield strength at 20°C by the factor  $k_{0,2\text{proof},\theta}$  in Table 7.1.

**Table 7.1** *Retention factors for strength and stiffness and parameter  $g_{2,\theta}$  at elevated temperature*

Temperature $\theta$ (°C)	Retention factor $k_{0,2proof,\theta}$	Parameter $g_{2,\theta}$	Retention factor $k_{u,\theta}$	Retention factor $k_{E,\theta}$
<b>Grade 1.4301</b>				
20	1,00	0,26	1,00	1,00
100	0,82	0,24	0,87	0,96
200	0,68	0,19	0,77	0,92
300	0,64	0,19	0,73	0,88
400	0,60	0,19	0,72	0,84
500	0,54	0,19	0,67	0,80
600	0,49	0,22	0,58	0,76
700	0,40	0,26	0,43	0,71
800	0,27	0,35	0,27	0,63
900	0,14	0,38	0,15	0,45
1000	0,06	0,40	0,07	0,20
1100	0,03	0,40	0,03	0,10
1200	0,00	0,40	0,00	0,00
<b>Grade 1.4401</b>				
20	1,00	0,24	1,00	1,00
100	0,88	0,24	0,93	0,96
200	0,76	0,24	0,87	0,92
300	0,71	0,24	0,84	0,88
400	0,66	0,21	0,83	0,84
500	0,63	0,20	0,79	0,80
600	0,61	0,19	0,72	0,76
700	0,51	0,24	0,55	0,71
800	0,40	0,35	0,34	0,63
900	0,19	0,38	0,18	0,45
1000	0,10	0,40	0,09	0,20
1100	0,05	0,40	0,04	0,10
1200	0,00	0,40	0,00	0,00
<b>Grade 1.4571</b>				
20	1,00	0,25	1,00	1,00
100	0,89	0,25	0,88	0,96
200	0,83	0,25	0,81	0,92
300	0,77	0,24	0,80	0,88
400	0,72	0,22	0,80	0,84
500	0,69	0,21	0,77	0,80
600	0,66	0,21	0,71	0,76
700	0,59	0,25	0,57	0,71
800	0,50	0,35	0,38	0,63
900	0,28	0,38	0,22	0,45
1000	0,15	0,40	0,11	0,20
1100	0,075	0,40	0,055	0,10
1200	0,00	0,40	0,00	0,00
<b>Grade 1.4462</b>				
20	1,00	0,35	1,00	1,00
100	0,91	0,35	0,93	0,96
200	0,80	0,32	0,85	0,92
300	0,75	0,30	0,83	0,88
400	0,72	0,28	0,82	0,84
500	0,65	0,30	0,71	0,80
600	0,56	0,33	0,57	0,76
700	0,37	0,40	0,38	0,71
800	0,26	0,41	0,29	0,63
900	0,10	0,45	0,12	0,45
1000	0,03	0,47	0,04	0,20
1100	0,015	0,47	0,02	0,10
1200	0,00	0,47	0,00	0,00

**Table 7.1** (continued) *Retention factors for strength and stiffness and parameter  $g_{2,\theta}$  at elevated temperature*

Temperature $\theta$ (°C)	Retention factor $k_{0,2proof,\theta}$	Parameter $g_{2,\theta}$	Retention factor $k_{u,\theta}$	Retention factor $k_{E,\theta}$
<b>Grade 1.4318</b>				
20	1.00	0.25	1.00	1.00
100	0.78	0.25	0.74	0.96
200	0.65	0.25	0.73	0.92
300	0.57	0.25	0.64	0.88
400	0.51	0.25	0.60	0.84
500	0.48	0.25	0.55	0.80
600	0.46	0.27	0.52	0.76
700	0.40	0.27	0.40	0.71
800	0.27	0.26	0.26	0.63
<b>Grade 1.4318 C850</b>				
20	1.00	0.21	1.00	1.00
100	0.86	0.24	0.71	0.91
200	0.77	0.25	0.61	0.88
300	0.69	0.24	0.60	0.84
400	0.68	0.24	0.57	0.80
500	0.65	0.25	0.53	0.76
600	0.54	0.25	0.45	0.72
700	0.40	0.26	0.34	0.67
800	0.23	0.25	0.24	0.52
900	0.11	0.25	0.10	0.35
<b>Grade 1.4571 C850</b>				
20	1.00	0.36	1.00	1.00
100	0.96	0.36	0.94	0.96
200	0.95	0.36	0.88	0.92
300	0.92	0.36	0.84	0.88
400	0.89	0.36	0.82	0.84
500	0.83	0.36	0.79	0.80
600	0.81	0.36	0.72	0.76
700	0.60	0.37	0.53	0.71
800	0.35	0.39	0.38	0.63
900	0.10	0.40	0.20	0.45

## 7.3 Thermal properties at elevated temperatures

### 7.3.1 Thermal elongation

The thermal elongation of austenitic stainless steel  $\Delta l/l$  may be determined from the following:

$$\Delta l/l = (16 + 4,79 \times 10^{-3} \theta_a - 1,243 \times 10^{-6} \theta_a^2) \times (\theta_a - 20) 10^{-6} \quad (7.3)$$

where:

$l$  is the length at 20°C

$\Delta l$  is the temperature induced expansion

$\theta_a$  is the steel temperature [°C]

### 7.3.2 Specific heat

The specific heat of stainless steel  $c_a$  may be determined from the following:

$$c_a = 450 + 0,280 \times \theta_a - 2,91 \times 10^{-4} \theta_a^2 + 1,34 \times 10^{-7} \theta_a^3 \text{ J/kgK} \quad (7.4)$$

where:

$\theta_a$  is defined in Section 7.3.1

### 7.3.3 Thermal conductivity

The thermal conductivity of stainless steel  $\lambda_a$  may be determined from the following:

$$\lambda_a = 14,6 + 1,27 \times 10^{-2} \theta_a \text{ W/mK} \quad (7.5)$$

where:

$\theta_a$  is defined in Section 7.3.1.

## 7.4 Determination of structural fire resistance

Fire resistance may be determined by one or more of the following approaches:

- simple calculation method applied to individual members
- advanced calculation method
- testing.

The simple calculation method is based on conservative assumptions. Advanced calculation methods are design methods in which engineering principles are applied in a realistic manner to specific applications. Where no simple calculation model is given, it is necessary to use either a design method based on an advanced calculation model or a method based on test results.

Advanced calculation methods are covered in the Commentary to these Recommendations (see Foreword).

### 7.4.1 Cross section classification

In fire design, the method of classification of cross-sections described in Section 4 of this document should be adopted, using design properties at 20°C.

### 7.4.2 Tension members

The design resistance  $N_{fi,\theta,Rd}$  of a tension member at a uniform temperature  $\theta_a$  should be determined from:

$$N_{fi,\theta,Rd} = k_{2,\theta} N_{Rd} [\gamma_{M0} / \gamma_{M,fi}] \quad (7.6)$$

where:

$k_{2,\theta} = f_{2,\theta} / f_y$  i.e. the retention factor for the strength at 2% total strain at temperature  $\theta_a$

$N_{Rd}$  is the design resistance of the cross-section  $N_{pl,Rd}$  for normal temperature design, according to Section 4.7.2.

$\gamma_{M0}$  and  $\gamma_{M,fi}$  are partial factors, see Table 2.1

Where the temperature in the member is non-uniform, the design resistance is given by:

$$N_{fi,t,Rd} = \sum_{i=1}^n A_i k_{2,\theta,i} f_y / \gamma_{M,fi} \quad (7.7)$$

where:

$A_i$  is an elemental area of the cross-section

$\theta_i$  is the temperature in the elemental area  $A_i$

$k_{2,\theta,i}$  is the retention factor for the strength at 2% total strain at temperature  $\theta_i$  (see Section 7.2).

Alternatively, the design resistance  $N_{fi,t,Rd}$  at time  $t$  of a tension member with a non-uniform temperature distribution may conservatively be taken as equal to the design resistance  $N_{fi,\theta,Rd}$  of a tension member with a uniform temperature  $\theta_a$  equal to the maximum temperature  $\theta_{a,max}$  reached at time  $t$ .

### 7.4.3 Compression members

The following recommendations apply to columns with Class 1, 2, 3 or 4 cross-sections that are:

- cold formed, open cross-sections (not welded), e.g. channels or angles, or
- cold formed hollow cross-sections (both seam welded or seamless), e.g. circular or rectangular hollow sections.

The design buckling resistance  $N_{b,fi,t,Rd}$  at time  $t$  of a compression member with a uniform temperature  $\theta_a$  is given by:

$$N_{b,fi,t,Rd} = \chi_{fi} A k_{0,2proof,\theta} f_y / \gamma_{M,fi} \quad \text{for Class 1, 2 or 3 sections} \quad (7.8)$$

$$N_{b,fi,t,Rd} = \chi_{fi} A_{eff} k_{0,2proof,\theta} f_y / \gamma_{M,fi} \quad \text{for Class 4 sections} \quad (7.9)$$

where:

$k_{0,2proof,\theta}$  is the 0,2% proof strength retention factor at temperature  $\theta_a$  (see Section 7.2).

$\chi_{fi}$  is the reduction factor for flexural buckling in fire, given by:

$$\chi_{fi} = \frac{1}{\varphi_{\theta} + \sqrt{\varphi_{\theta}^2 - \bar{\lambda}_{\theta}^2}} \quad \text{but } \chi_{fi} \leq 1 \quad (7.10)$$

$$\text{where: } \varphi_{\theta} = 0,5 \left( 1 + \alpha (\bar{\lambda}_{\theta} - \bar{\lambda}_0) + \bar{\lambda}_{\theta}^2 \right) \quad (7.11)$$

in which  $\alpha$  and  $\bar{\lambda}_0$  are the room temperature buckling coefficients given in Table 5.1.

The modified non-dimensional slenderness  $\bar{\lambda}_{\theta}$  at temperature  $\theta$  is given by:

$$\bar{\lambda}_{\theta} = \bar{\lambda} \left[ \frac{k_{0,2proof,\theta}}{k_{E,\theta}} \right]^{0,5} \quad \text{for all Classes of cross-section} \quad (7.12)$$

where:

$k_{E,\theta}$  is the retention factor for the slope of the linear elastic range at temperature  $\theta_a$  (see Section 7.2).

Where the temperature of the member is non-uniform, the compression resistance may conservatively be estimated by assuming a uniform temperature that is equal to the maximum temperature in the member.

The buckling length  $l_{fi}$  of a column for fire design should generally be determined as for normal temperature design. However, in a braced frame, the buckling length  $l_{fi}$  may be determined by considering the column as fixed in direction at continuous or semi-continuous connections to the column lengths in the fire compartments above and below. This assumption can only be made if the fire resistance of the building components that separate these fire compartments is not less than the fire resistance of the column.

In the case of a braced frame in which each storey comprises a separate fire compartment with sufficient fire resistance, the buckling length of a column in an intermediate storey is given by  $l_{fi} = 0,5L$  and in the top storey the buckling length is given by  $l_{fi} = 0,7L$ , where  $L$  is the system length in the relevant storey, see Figure 7.1.

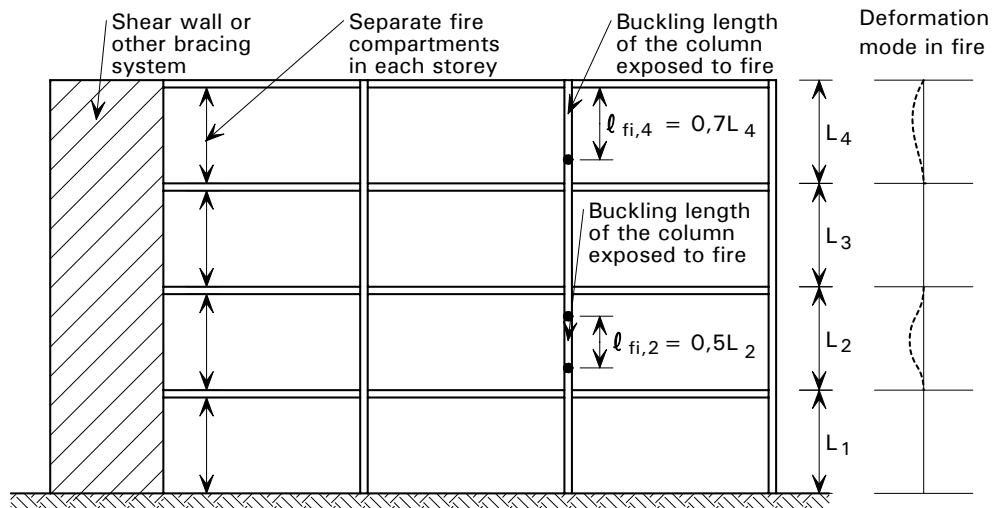


Figure 7.1 Buckling lengths  $l_{fi}$  of columns in braced frames

#### 7.4.4 Laterally restrained beams

The design moment resistance  $M_{fi,\theta,Rd}$  of a cross-section at a uniform temperature  $\theta_a$  should be determined from:

$$M_{fi,\theta,Rd} = k_{2,\theta} [\gamma_{M0} / \gamma_{M,fi}] M_{Rd} \quad \text{for Class 1, 2 or 3 cross-sections (7.13)}$$

$$M_{fi,\theta,Rd} = k_{0,2proof,\theta} [\gamma_{M0} / \gamma_{M,fi}] M_{Rd} \quad \text{for Class 4 cross-sections (7.14)}$$

where:

$M_{Rd}$  is the design plastic moment resistance of the gross cross-section  $M_{pl,Rd}$  (Class 1 or 2 cross-sections), the elastic moment resistance of the gross cross-section  $M_{el,Rd}$  (Class 3 cross-sections) or effective moment resistance of the effective cross section  $M_{eff,Rd}$  (Class 4 cross-sections) for normal temperature design

$k_{2,\theta}$  and  $k_{0,2proof,\theta}$  are as defined in Section 7.4.3.



Where it is necessary to allow for the effects of shear, the reduced moment resistance for normal temperature design according to Section 4.7.6 should be used.

The design moment resistance  $M_{fi,t,Rd}$  at time  $t$  of a cross-section in a member with a non-uniform temperature distribution, may conservatively be determined from:

$$M_{fi,t,Rd} = M_{fi,\theta,Rd} / \kappa_1 \kappa_2 \quad (7.15)$$

where:

$M_{fi,\theta,Rd}$  is the design moment resistance of the cross-section (or effective cross section for Class 4 cross-section) at a uniform temperature  $\theta_a$  equal to the maximum temperature in the cross-section

$\kappa_1$  is an adaptation factor for non-uniform temperature across the cross-section, see Table 7.2

$\kappa_2$  is an adaptation factor for non-uniform temperature along the beam, see Table 7.2.

**Table 7.2** *Adaptation factors*

Exposure condition	$\kappa_1$
for a beam exposed to fire on all four sides	1,0
for an unprotected beam exposed to fire on three sides, with a composite or concrete slab on its fourth side	0,70
for a protected beam exposed to fire on three sides, with a composite or concrete slab on its fourth side	0,85
	$\kappa_2$
at the supports of a statically indeterminate beam	0,85
in all other cases	1,0

The design shear resistance  $V_{fi,t,Rd}$  at time  $t$  of a cross-section with a non-uniform temperature distribution should be determined from:

$$V_{fi,t,Rd} = k_{2,\theta,web} V_{Rd} [\gamma_{M0} / \gamma_{M,fi}] \quad \text{for Class 1, 2 or 3 cross-sections} \quad (7.16)$$

$$V_{fi,t,Rd} = k_{0,2proof,\theta,web} V_{Rd} [\gamma_{M0} / \gamma_{M,fi}] \quad \text{for Class 4 cross-sections} \quad (7.17)$$

where:

$V_{Rd}$  is the shear resistance of the gross cross-section for normal temperature design, according to Section 4.7.5 (for temperatures above 400°C,  $\eta$  should be taken as 1,0).

$\theta_{web}$  is the temperature in the web of the section.

#### 7.4.5 Laterally unrestrained beams

The design buckling resistance moment  $M_{b,fi,t,Rd}$  at time  $t$  of a laterally unrestrained beam should be determined from:

$$M_{b,fi,t,Rd} = \chi_{LT,fi} W_{pl,y} k_{0,2proof,\theta} f_y / \gamma_{M,fi} \quad \text{for Class 1 and 2 sections} \quad (7.18)$$

$$M_{b,fi,t,Rd} = \chi_{LT,fi} W_{el,y} k_{0,2proof,\theta} f_y / \gamma_{M,fi} \quad \text{for Class 3 sections} \quad (7.19)$$

$$M_{b,fi,t,Rd} = \chi_{LT,fi} W_{eff,y} k_{0,2proof,\theta} f_y / \gamma_{M,fi} \quad \text{for Class 4 sections} \quad (7.20)$$

where:

$\chi_{LT,fi}$  is the reduction factor for lateral-torsional buckling in fire, given by:

$$\chi_{LT,fi} = \frac{1}{\varphi_{LT,\theta} + \sqrt{\varphi_{LT,\theta}^2 - \bar{\lambda}_{LT,\theta}^2}} \text{ but } \chi_{LT,fi} \leq 1 \quad (7.21)$$

$$\text{and } \varphi_{LT,\theta} = 0,5 \left( 1 + \alpha_{LT} (\bar{\lambda}_{LT,\theta} - 0,4) + \bar{\lambda}_{LT,\theta}^2 \right) \quad (7.22)$$

in which  $\alpha_{LT}$  is the room temperature imperfection factor given in Section 5.4.2.

$k_{0,2proof,\theta}$  is the retention factor defined in Section 7.4.3 at the maximum temperature  $\theta$  reached anywhere in the section.

The non-dimensional slenderness  $\bar{\lambda}_{LT,\theta}$  at temperature  $\theta$  is given by:

$$\bar{\lambda}_{LT,\theta} = \bar{\lambda}_{LT} \left[ \frac{k_{0,2proof,\theta}}{k_{E,\theta}} \right]^{0,5} \text{ for all Classes of cross-section} \quad (7.23)$$

where:

$k_{E,\theta}$  is the reduction factor defined in Section 7.4.3 at temperature  $\theta$ .

#### 7.4.6 Members subject to axial compression and bending

The combined effects of compressive loads and bending moments should be checked in accordance with the following expressions to prevent premature major and minor axis buckling and lateral torsional buckling:

a) For Class 1, 2 or 3 cross-sections

$$\frac{N_{fi,Ed}}{\chi_{min,fi} A k_{0,2proof,\theta} \frac{f_y}{\gamma_{M,fi}}} + \frac{k_y M_{y,fi,Ed}}{M_{y,fi,\theta,Rd}} + \frac{k_z M_{z,fi,Ed}}{M_{z,fi,\theta,Rd}} \leq 1 \quad (7.24)$$

$$\frac{N_{fi,Ed}}{\chi_{min1,fi} A k_{0,2proof,\theta} \frac{f_y}{\gamma_{M,fi}}} + \frac{k_{LT} M_{y,fi,Ed}}{\chi_{LT,fi} M_{y,fi,\theta,Rd}} + \frac{k_z M_{z,fi,Ed}}{M_{z,fi,\theta,Rd}} \leq 1 \quad (7.25)$$

where:

$N_{fi,Ed}$ ,  $M_{y,fi,Ed}$  and  $M_{z,fi,Ed}$  are the axial design load and bending moments for the fire situation

$M_{y,fi,\theta,Rd}$  and  $M_{z,fi,\theta,Rd}$  are as defined in Section 7.4.4

$k_{0,2proof,\theta}$  is the reduction factor at temperature  $\theta$ , as defined in Section 7.4.3

$\chi_{min,fi}$  is the smallest reduction factor for flexural, torsional and torsional-flexural buckling at temperature  $\theta$ , as defined in Section 7.4.3

$\chi_{min1,fi}$  is the smallest reduction factor for flexural buckling about the z axis, torsional and torsional-flexural buckling at temperature  $\theta$ , as defined in Section 7.4.3

$\chi_{LT,fi}$  is the reduction factor for lateral torsional buckling at temperature  $\theta$ , as defined in Section 7.4.5.

$$k_{LT} = 1 - \frac{\mu_{LT} N_{fi,Ed}}{\chi_{z,fi} A k_{0,2proof,\theta} \frac{f_y}{\gamma_{M,fi}}} \leq 1 \quad (7.26)$$

$$\mu_{LT} = 0,15 \bar{\lambda}_{z,\theta} \beta_{M,LT} - 0,15 \leq 0,9 \quad (7.27)$$

$$k_y = 1 - \frac{\mu_y N_{fi,Ed}}{\chi_{y,fi} A k_{0,2proof,\theta} \frac{f_y}{\gamma_{M,fi}}} \leq 3 \quad (7.28)$$

$$\mu_y = (1,2 \beta_{M,y} - 3) \bar{\lambda}_{y,\theta} + 0,44 \beta_{M,y} - 0,29 \leq 0,8 \quad (7.29)$$

$$k_z = 1 - \frac{\mu_z N_{fi,Ed}}{\chi_{z,fi} A k_{0,2proof,\theta} \frac{f_y}{\gamma_{M,fi}}} \leq 3 \quad (7.30)$$

$$\mu_z = (2 \beta_{M,z} - 5) \bar{\lambda}_{z,\theta} + 0,44 \beta_{M,z} - 0,29 \leq 0,8 \quad \text{and} \quad \bar{\lambda}_{z,\theta} \leq 1,1 \quad (7.31)$$

$\beta_M$  is an equivalent uniform moment factor, given in Table 7.3.

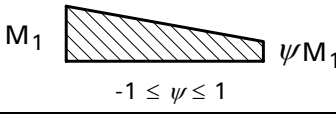
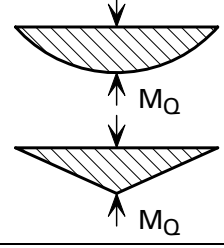
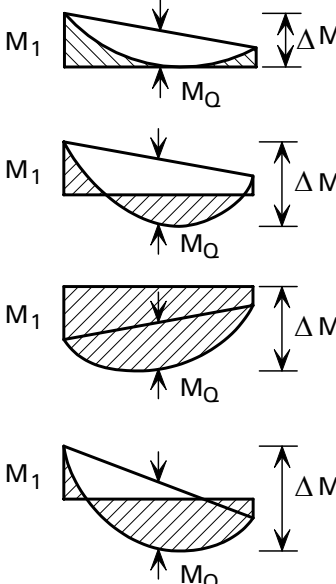
b) For Class 4 cross-sections:

$$\frac{N_{fi,Ed}}{\chi_{\min,fi} A_{\text{eff}} k_{0,2proof,\theta} \frac{f_y}{\gamma_{M,fi}}} + \frac{k_y M_{y,fi,Ed} + N_{fi,Ed} e_y}{M_{y,fi,\theta,Rd}} + \frac{k_z M_{z,fi,Ed} + N_{fi,Ed} e_z}{M_{z,fi,\theta,Rd}} \leq 1 \quad (7.32)$$

$$\frac{N_{fi,Ed}}{\chi_{\min 1,fi} A_{\text{eff}} k_{0,2proof,\theta} \frac{f_y}{\gamma_{M,fi}}} + \frac{k_{LT} M_{y,fi,Ed} + N_{fi,Ed} e_y}{\chi_{LT,fi} M_{y,fi,\theta,Rd}} + \frac{k_z M_{z,fi,Ed} + N_{fi,Ed} e_z}{M_{z,fi,\theta,Rd}} \leq 1 \quad (7.33)$$

where the terms are defined in (a) above except that in the calculation of  $k_y$ ,  $k_z$  and  $k_{LT}$ ,  $A$  should be replaced by  $A_{\text{eff}}$ .

**Table 7.3** Equivalent uniform moment factors,  $\beta_M$

Moment diagram	Equivalent uniform moment factor $\beta_M$
<p>End moments</p>  <p><math>M_1</math> <math>\psi M_1</math>  <math>-1 \leq \psi \leq 1</math></p>	$\beta_{M,\psi} = 1,8 - 0,7 \psi$
<p>Moments due to in-plane lateral loads</p>  <p><math>M_Q</math>  <math>M_Q</math></p>	$\beta_{M,\alpha} = 1,3$ $\beta_{M,\alpha} = 1,4$
<p>Moments due to in-plane lateral loads plus end moments</p>  <p><math>M_1</math> <math>M_Q</math> <math>\Delta M</math>  <math>M_1</math> <math>M_Q</math> <math>\Delta M</math>  <math>M_1</math> <math>M_Q</math> <math>\Delta M</math>  <math>M_1</math> <math>M_Q</math> <math>\Delta M</math></p>	$\beta_M = \beta_{M,\psi} + \frac{M_Q}{\Delta M} (\beta_{M,\alpha} - \beta_{M,\psi})$ $M_\alpha =  \max M $ due to lateral load only  For moment diagram without change of sign: $\Delta M =  \max M $  For moment diagram with change of sign: $\Delta M =  \max M  +  \min M $

#### 7.4.7 Calculation of temperature rise in stainless steel

The method for calculating the temperature rise in carbon steel can also be applied to stainless steel.

The incremental rise in temperature of a uniformly heated bare stainless steel section in time interval  $\Delta t$  is given by:

$$\Delta\theta_{a,t} = \frac{A_m/V}{c_a \rho_a} \dot{h}_{\text{net,d}} \Delta t \quad (7.34)$$

where:

$c_a$  is the specific heat of stainless steel, (J/kgK), as given in Section 7.3.2

$\rho_a$  is the density of stainless steel ( $\text{kg/m}^3$ ), as given in Table 3.6 (usually considered as temperature independent)

$A_m/V$  is the section factor for unprotected steel members

$A_m$  is the surface area of the member per unit length  
 $V$  is the volume of the member per unit length  
 $\dot{h}_{net,d}$  is the design value of the net heat flux per unit area

$$= \dot{h}_{net,c} + \dot{h}_{net,r} \quad (7.35)$$

in which:

$$\dot{h}_{net,c} = \alpha_c (\theta_g - \theta_a) \quad (7.36)$$

$$\dot{h}_{net,r} = \varphi \varepsilon_{res} 5,67 \times 10^{-8} [(\theta_g + 273)^4 - (\theta_a + 273)^4] \quad (7.37)$$

$\alpha_c$  is the coefficient of heat transfer by convection (usually taken as 25W/m<sup>2</sup>K)

$\theta_g$  is the gas temperature of the environment of the member in fire exposure (°C), given by the nominal temperature-time curve

$\theta_a$  is the temperature of the steel section which is assumed to be uniform at time  $t$  (°C)

$\varphi$  is the configuration factor

$\varepsilon_{res}$  is the resultant emissivity.

The parameter  $\varepsilon_{res}$  represents the radiation transmitted between the fire and the stainless steel surface and its magnitude depends on the degree of direct exposure of the element to the fire. Elements which are partially shielded from the radiant effects of the heat of the fire would have a lower value of  $\varepsilon_{res}$ . For stainless steel,  $\varepsilon_{res}$  can be taken as 0,2.

The above equation for the incremental temperature rise may be used to determine steel temperatures by incremental integration, if the variation of the fire temperature with time is known. The nominal temperature-time curve for a cellulosic fire is given in EN 1991-1-2 as:

$$\theta_g = 20 + 345 \log_{10}(8t + 1) \quad (7.38)$$

where:

$t$  is the elapsed time (minutes).

## 8 FATIGUE

Consideration should be given to metal fatigue in structures or parts of structures subjected to significant levels of repeated stress. No fatigue assessment is normally required for building structures, except for members supporting lifting appliances, rolling loads or vibrating machinery, and for members subject to wind-induced oscillation.

In common with carbon steel structures, the combination of stress concentrations and defects at welded joints leads to these locations being almost invariably more prone to fatigue failure than other parts of the structure. Guidance on estimating the fatigue strength of carbon steel structures is applicable to stainless steels (see EN 1993-1-9).

Much can be done to reduce the susceptibility of a structure to fatigue by adopting good design practice. This involves judiciously selecting the overall structural configuration and carefully choosing constructional details that are fatigue resistant. The key to fatigue resistant design is a rational consideration of fatigue early in the design process. A fatigue assessment performed only after other design criteria have been satisfied may result in an inadequate or costly structure. It is also important to consider the needs of the fabricator and erector. It is therefore recommended that early consultations be held with them to point out areas of the structure which are most sensitive to fatigue cracking, to discuss special precautions and to become aware of fabrication and erection problems. In particular, the use of holes or lifting attachments to ease fabrication or erection should be considered during the fatigue evaluation.

It may be possible to eliminate potential fatigue problems by giving due regard to constructional details and avoiding:

- sharp changes in cross-section and stress concentrations in general
- misalignments and eccentricities
- small discontinuities such as scratches and grinding marks
- unnecessary welding of secondary attachments, e.g. lifting lugs
- partial penetration welds, fillet welds, intermittent welding, and backing strips
- arc strikes.

Although weld improvement techniques such as weld profile control, weld toe grinding, and shot and hammer peening may improve the fatigue strength of a joint, there are insufficient data to quantify the possible benefits for stainless steel. It should also be noted that the techniques are all labour-intensive and require skill and experience of the operator to achieve maximum benefit. They should not, except in special cases, be seen as a design option.

## 9 TESTING

### 9.1 General

Testing of stainless steel materials and members may be required for a number of reasons:

- If the design is to be based on actual material data (see Section 3.2.4).
- If advantage is to be taken of the strength enhancement of cold formed corners in members (see Sections 3.2.2 and 4.7.1).
- If the geometry of a member is such that it lies outside applicable limits (such as those given in Section 4.2).
- If a number of structures or components are to be based on prototype testing.
- If confirmation of consistency of production is required.

The usual precautions and requirements for test procedures and results evaluation appertaining to carbon steel testing also apply to stainless steel testing. It is therefore generally recommended that such requirements are consulted, e.g. see Section 5.2 and Annex D of EN 1990 and Section 9 and Annex A of EN 1993-1-3. However, there are particular aspects of the behaviour of stainless steels which need to be given more thought in the design of the tests than perhaps would be the case for carbon steels. The following brief guidance is offered.

### 9.2 Stress-strain curve determination

The applicable European Standard for material tests is EN 10002-1 *Tensile testing of metallic materials. Method of test at ambient temperature*. This standard does not give end details for the test coupons, although the diagrams suggest that the ends would be gripped. However, it is recommended that loading should be accomplished by pins passing through the ends of the coupon which are of sufficient area to sustain the shear. This is to ensure the coupon is axially loaded, thus enabling the actual shape of the stress-strain curve to be discerned without any spurious effect caused by premature yielding due to load eccentricity. Axiality of loading may be confirmed by elastic tests with an extensometer placed at various orientations about the specimen.

Cognisance should be taken of strain-rate effects, see Section 3.2.2.

### 9.3 Tests on members

It is recommended that member tests should be full scale or as near to full scale as possible, depending on test facilities, and that the specimens should be manufactured by the same fabrication processes to be used in the final structure. If the components are welded, the prototype should be welded in the same way.

Since stainless steel may exhibit anisotropy, it is recommended that the specimens are prepared from the plate or sheet in the same orientation (i.e. transverse or parallel to the rolling direction) as intended for the final structure.

If the final orientation is unknown or cannot be guaranteed, it may be necessary to conduct tests for both orientations and take the less favourable set of results.

Stainless steel displays higher ductility and greater strain hardening than carbon steel and therefore the test rig capabilities may need to be greater than those required for testing carbon steel members of equivalent material yield strength. This not only applies to rig loading capacity but also to the ability of the rig to allow greater deformation of the specimen.

It should be noted that at higher specimen loads, the effects of creep become more manifest and this may mean that strain or displacement readings do not stabilise within a reasonable time.

For work hardened materials, both the tensile and compressive strength should be determined in the direction in question. Evaluation of the test results should be carried out with the relevant strength as reference.



# 10 FABRICATION ASPECTS

## 10.1 Introduction

The purpose of this Section is to highlight relevant aspects of stainless steel fabrication for the design engineer, including recommendations for good practice. It also allows a preliminary assessment to be made of the suitability of a fabricator to perform the work.

Stainless steel is not a difficult material to work with. However, in some respects it is different from carbon steel and should be treated accordingly. Many fabrication and joining processes are similar to those used for carbon steel, but the different characteristics of stainless steel require special attention in a number of areas. It is important that effective communication is established between the designer and fabricator early in the project to ensure that appropriate fabrication practices can and will be adopted.

An overriding objective is to maintain the steel's corrosion resistance. It is essential that precautions are taken at all stages of storing, handling and forming to minimise influences that jeopardise the formation of the self-repairing passive layer. Special care must be taken to restore the full corrosion resistance of the welded zone. Although essential, the precautions are simple and, in general, are matters of good engineering practice.

It is important to preserve the good surface appearance of stainless steel throughout fabrication. Not only are surface blemishes unsightly, but they are usually unacceptable and prove time-consuming and expensive to correct. Whereas surface blemishes will normally be hidden by paint in carbon steel structures, this will only rarely be the case for stainless steel structures.

The structural form may be dictated by the availability of materials. It should be recognised that the available range of hot rolled stainless steel sections is more limited than for carbon steel. This results in a greater use of cold formed and welded members than is normally encountered. Also, because of brake press length capabilities, only relatively short lengths can be formed, which leads to an increased use of splices. In detailing joints, consideration should be given to clearances for bolts near bend radii and to potential fit up problems arising from weld distortion.

The guidance on fabrication and erection is in accordance with ENV 1090-6 *Execution of steel structures. Supplementary rules for stainless steel*. This standard is currently being converted into EN 1090 *Execution of steel structures and aluminium structures*. EN 1090-1 will give rules for using CE marks on steel structures. EN 1090-2 will include execution classes dependent on the type of steel structure; specific fabrication and erection requirements will correspond to the different execution classes. It is expected that EN 1090-2 will be submitted for final vote at the beginning of 2007.

The relevant standard for welding stainless steels is EN 1011-3 *Welding. Recommendations for welding of metallic materials. Arc welding of stainless steels*.

## 10.2 Storage and handling

Generally, greater care is required in storing and handling stainless steel than carbon steel to avoid damaging the surface finish (especially for bright annealed or polished finishes) and to avoid contamination by carbon steel and iron. Storage and handling procedures should be agreed between the relevant parties to the contract in advance of any fabrication and in sufficient detail to accommodate any special requirements. The procedures should cover, for instance, the following items:

- The steel should be inspected immediately after delivery for any surface damage.
- The steel may have a protective plastic or other coating. This should be left on as long as possible, removing it just before final fabrication. The protective covering should be called for in the procurement document if it is required (e.g. for bright annealed finishes).
- Storage in salt-laden humid atmospheres should be avoided. Storage racks should not have carbon steel rubbing surfaces and should, therefore, be protected by wooden, rubber or plastic battens or sheaths. Sheets and plates should preferably be stacked vertically; horizontally stacked sheets may get walked on with a risk of iron contamination and surface damage.
- Carbon steel lifting tackle, e.g. chains, hooks, and cleats should be avoided. Again, the use of isolating materials, or the use of suction cups, will prevent iron pick-up. The forks of fork lift trucks should also be protected.
- Contact with chemicals including undue amounts of oils and greases (which may stain some finishes) should be avoided.
- Ideally, segregated fabrication areas for carbon steel and stainless steel should be used. Only tools dedicated to stainless steel should be employed (this particularly applies to grinding wheels and wire brushes). Note that wire brushes and wire wool should be of stainless steel and generally in a grade that is equivalent in terms of corrosion resistance (e.g. do not use ferritic stainless steel brushes on austenitic stainless steel).
- As a precaution during fabrication and erection, it is advisable to ensure that any sharp burrs formed during shearing operations are removed.
- Consideration should be given to any requirements needed in protecting the finished fabrication during transportation.

## 10.3 Shaping operations

Austenitic stainless steels work harden significantly during cold working. This can be both a useful property, enabling extensive forming during stretch forming without risk of premature fracture, and a disadvantage, especially during machining when special attention to cutting feeds and speeds is required. The rate of work hardening differs with different grades, for example grade 1.4318 work hardens at a greater rate than other grades used in construction applications.

### 10.3.1 Cutting

Stainless steel is a relatively expensive material compared to some other metals and care is needed in marking out plates and sheets to avoid wastage in cutting.

Note that more wastage may result if the material has a polishing grain (or a unidirectional pattern) which has to be maintained in the fabrication. Some marking pens/crayons will prove difficult to remove, or cause staining, if used directly on the surface (rather than on any protective film); checks should be made that markers are satisfactory.

Stainless steel may be cut using usual methods, e.g. shearing and sawing, but power requirements will be greater than those for similar thicknesses of carbon steel, due to work hardening. If possible, cutting (and machining in general) should be carried out when the metal is in the annealed (softened) state, to limit work hardening and tool wear.

For cutting straight lines, guillotine shearing is widely used. By using open ended guillotines, a continuous cut greater in length than the shear blades can be achieved, although at the risk of introducing small steps in the cut edge.

Plasma arc techniques are also used and are particularly useful for cutting thick plates and profiles and where the cut edges are to be machined, e.g. for weld preparation. Oxyacetylene cutting is not satisfactory for cutting stainless steel, unless a powder fluxing technique is used.

### **10.3.2 Cold forming**

Stainless steel is readily shaped by commonly used cold forming techniques such as bending, spinning, pressing and deep drawing. For structural applications press brake bending is the most relevant technique though, for high volume thin gauge products, roll forming may be more economic.

Again, the power requirement for bending stainless steel will be higher than for bending carbon steel due to work hardening (by about 50% in the case of the austenitic stainless steels or more in the case of duplex grades). Also, stainless steel has to be overbent to a slightly higher degree than carbon steel to counteract the effects of springback. For complex cross-sections, it is prudent to involve the fabricator as early as possible in the design.

Stainless steel's high ductility allows small radii to be formed, perhaps as low as half the thickness in annealed materials. However, it is generally recommended to adopt the following internal radii as minima:

$2t$  for austenitic grades

$2,5t$  for duplex grades

where  $t$  is the thickness of the material.

When bending tubulars, the following guidance may be given:

- the outer tube diameter to wall thickness ratio should not exceed 15 (to avoid costly tooling).
- the bend radius (to centreline of tube) should not be less than  $2,5d$  where  $d$  is the outer diameter
- any welding bead should be positioned close to the neutral axis to reduce the bending stresses at the weld.

### **10.3.3 Holes**

Holes may be drilled or punched. In drilling, positive cutting must be maintained to avoid work hardening and this requires sharp bits with correct

angles of rake and correct cutting speeds. The use of a round tipped centre punch is not recommended as this work hardens the surface. Either a centre drill should be used or if a centre punch has to be used, it should be of the triangular pointed type. Punched holes can be made in austenitic stainless steel up to about 20 mm in thickness; the higher strength of duplex grades leads to a smaller limiting thickness. The minimum diameter of hole that can be punched out is 2 mm greater than the sheet thickness. Punched holes should be avoided in corrosive environments, due to the presence of the work hardened edge.

## 10.4 Welding

### 10.4.1 Introduction

The welding of austenitic and duplex stainless steels is widely and successfully carried out using normal processes, provided that suitable consumables are used. General cleanliness and the absence of contamination are important for attaining good weld quality. Oils or other hydrocarbons and wax crayon marks should be removed, to avoid their decomposition and the risk of carbon pick-up. The weld should be free from zinc, including that arising from galvanised products, and from copper and its alloys. (Care needs to be taken when copper backing bars are used; a groove should be provided in the bar immediately adjacent to the fusion area.)

It is more important in stainless steel than carbon steel to reduce sites at which crevice corrosion (see Section 3.7.2) may initiate. Welding deficiencies such as undercut, lack of penetration, weld spatter, slag and stray arc strikes are all potential sites and should thus be minimised. Stray arc strikes or arcing at loose earth connections also damage the passive layer, and possibly give rise to preferential corrosion, thereby ruining the appearance of a fabrication.

Where the weld appearance is important, the engineer should specify the as-welded profile and surface condition required. This may influence the welding process selected or the post weld treatment. Consideration should also be given to the location of the weld; is it possible to apply the appropriate post weld treatment?

Heat input and interpass temperatures need to be controlled to minimise distortion (see Section 10.4.4) and to avoid potential metallurgical problems (see Section 10.4.5).

Welding should be carried out to an approved welding procedure according to a standard such as EN ISO 15609-1 *Specification and qualification of welding procedures for metallic materials. Welding procedure specification. Arc welding*. Welders should be approved in accordance with EN 287-1 *Qualification test of welders. Fusion welding. Steels*. Welding procedures contain the following elements:

- verification of the welding method by detailing the derivation and testing requirements of weld procedures
- the qualifications of welders
- the control of welding operations during preparation, actual welding and post-weld treatment
- the level of inspection and non-destructive testing techniques to be applied

- the acceptance criteria for the permitted level of weld defects.

Provided that suitable procedures are followed, welding problems should not occur. However, the engineer should be aware that welding distortion is generally greater in stainless steel than in carbon steel, see Section 10.4.4.

Lock welding of the nut to the bolt should never be allowed, as the materials are formulated for strength and not for fusion welding.

### 10.4.2 Processes

As mentioned above, the common fusion methods of welding can be used on stainless steel. Table 10.1 shows the suitability of various processes for thickness ranges, etc. In MIG or TIG welding, the shielding gas should not contain carbon dioxide due to the possibility of decomposition leading to carbon pick-up and, in the case of duplex grades, nitrogen should be also avoided.

**Table 10.1** *Welding processes and their suitability*

Weld process (EN ISO 4063)	Suitable product forms	Types of welded joint	Material thickness range	Weld positions	Suitable shop/site conditions
111 Metal arc welding with covered electrode (Manual metal arc)	All but not sheet	All	3 mm <sup>(1)</sup> or greater	All	All
131 Metal arc inert gas (MIG)	All	All	2 mm <sup>(1)</sup> or greater	All	All <sup>(2)</sup>
141 Tungsten inert gas (TIG)	All	All	Up to 10 mm maximum	All	All <sup>(2)</sup>
121/122 Submerged arc welding	All but not sheet	All	3 mm <sup>(1)</sup> or greater	Downhand positions only	All
2 Resistance welding	Sheet only	All	3 mm maximum approximate	All	All

Notes:

1) Depends upon type of weld joint used.

2) More sensitive to weather than other processes and better environmental protection is required.

### 10.4.3 Consumables

Commercial consumables have been formulated to give weld deposits of equivalent strength and corrosion resistance to the parent metal and to minimise the risk of solidification cracking. For specialist applications, such as unusually aggressive environments or where non-magnetic properties are required, the advice of steel producers and manufacturers of consumables should be sought. All consumables should be kept free from contaminants and stored according to the manufacturer's instructions.

All welding consumables should conform to the requirements specified in ENV 1090 (to be superseded by EN 1090-2). It is important that consumables are kept free from contaminants and stored according to the manufacturer's instructions.

#### 10.4.4 Welding distortion

In common with other metals, stainless steel suffers from distortion due to welding. The types of distortion (angular, bowing, shrinkage etc.) are similar in nature to those found in carbon steel structures. However, the distortion of stainless steel, particularly of austenitic grades, is greater than that of carbon steel because of higher coefficients of thermal expansion and lower thermal conductivities (which lead to steeper temperature gradients), see Section 3.3.

Welding distortion can only be controlled, not eliminated. The following actions may be taken by the designer and the fabricator:

##### ***Designer actions***

- Remove the necessity to weld.
- Reduce the extent of welding.
- Reduce the area of welds. For instance in thick sections, specify double V, U or double U preparations in preference to single V.
- Use symmetrical joints.
- Design to accommodate wider dimensional tolerances.

##### ***Fabricator actions***

- Use efficient clamping jigs. If possible the jig should incorporate copper or aluminium bars to help conduct heat away from the weld area.
- When efficient jiggling is not possible, use closely spaced tack welds laid in a balanced sequence.
- Ensure that good fit up and alignment is obtained prior to welding.
- Use the lowest heat input commensurate with the selected weld process.
- Use balanced welding and appropriate sequences (e.g. backstepping and block sequences).

#### 10.4.5 Metallurgical considerations

It is not possible to cover here the metallurgy of stainless steels except for some of the more significant factors.

##### ***Formation of precipitates in the austenitic grades***

In the austenitic steels, the heat affected zone is relatively tolerant to grain growth and to the precipitation of brittle and intermetallic phases. Welding procedures are usually designed to control the time spent in the critical temperature range for precipitation effects (450 - 900°C). Excessive weld repair naturally increases the time spent and is thus usually restricted to three major repairs.

The formation of chromium carbide precipitates, and the ensuing loss of corrosion resistance, is discussed in Section 3.7.2 *Intergranular corrosion* where it is noted that this is not normally a problem with the low carbon grades of austenitic stainless steel (i.e. 1.4307 and 1.4404). However, weld decay effects may be manifested in the standard carbon grades in welded construction involving plate thickness greater than about 10 mm.

### ***Solidification cracking in the austenitic grades***

Solidification cracking of welds is avoided when the weld structure contains approximately 5% ferrite. Steelmakers balance the composition and heat treatment of the common grades of austenitic steel to ensure that they contain virtually no ferrite when delivered but will form sufficient ferrite in an autogenous weld (i.e. a weld with no filler added). Even so, to reduce any likelihood of cracking, it is prudent to minimise heat inputs, interpass temperatures and restraint when making autogenous welds. In thicker materials filler metal is added and the use of good quality consumables will again ensure the appropriate amount of ferrite is formed. It is not normally necessary to measure the precise amount of ferrite formed; appropriate weld procedures and consumables will ensure that solidification cracking will not occur.

### ***Embrittlement of duplex grades***

Duplex steels are sensitive to 475°C and  $\sigma$ -phase embrittlement. The former occurs when the steel is held within or cooled slowly through the approximate temperature range 550°C to 400°C and this produces an increase in tensile strength and hardness with a decrease in tensile ductility and impact strength. The latter might occur after a long exposure at a temperature in the range 565°C to 900°C but can occur in as short as half an hour under appropriate conditions (depending on the composition and the thermo-mechanical state of the steel). The effects of  $\sigma$ -phase embrittlement are greatest at room temperature. Both forms of embrittlement have an adverse effect on corrosion resistance and toughness.

Both 475°C and  $\sigma$ -phase embrittlement can be adequately controlled by adopting correct welding procedures; a maximum interpass temperature of 200°C is suggested. Particular care must be exercised when welding heavy sections.

To avoid embrittlement, long term exposure at temperatures above 300°C should be avoided.

### **10.4.6 Post weld treatment**

It is best, both technically and commercially, to produce structures by welding. Post weld treatment is generally necessary, as discussed in the following paragraphs, especially if arc welding processes are involved. It is important to define the required post weld treatment for avoiding cost overruns and possible poor service performance. Finishing techniques common to all fabrications are covered in Section 10.6

The processes usually employed for weld dressing are wire brushing, and grinding. The amount of dressing should be minimised by the fabricator and if possible limited to wire brushing. This is because the heat produced in grinding can affect the corrosion resistance. Note that wire brushes should be made of stainless steel (see Section 10.2).

It is good practice to remove all traces of heat tint. However, yellow heat tint may prove satisfactory when the stainless steel offers a good margin of resistance for the particular environment. Where this is not so, or where the tint is not acceptable on aesthetic grounds, it may be removed by pickling or glass bead blasting. Pickling may be carried out by immersion in a bath (see Section 10.6) or by using pastes in accordance with the manufacturer's instructions.

Peening the surface of a weld is a beneficial post weld treatment. It introduces compressive stresses into the surface which improves fatigue and stress corrosion cracking resistance and aesthetic appearances. However, peening cannot be used to justify a change in fatigue assessment.

The action of removing metal during substantial machining will give rise to stress relieving and hence distortion of the as-welded product. In those cases where the distortion is such that dimensional tolerances cannot be achieved, a thermal stress treatment will be required. Generally, this will only be an option for small sized components and only for grades which resist sensitisation (see Section 3.7.2) such as the low carbon grades 1.4307 and 1.4404 or the stabilised grades 1.4541 and 1.4571.

#### 10.4.7 Inspection of welds

Table 10.2 shows the inspection methods commonly used on stainless steel welds and on carbon steel welds.

The methods are used as necessary depending on the degree of structural and corrosion integrity required for the environment under consideration. However, visual inspection should be carried out during all stages of welding as it can prevent many problems becoming troublesome as fabrication continues. Surface examination of stainless steel is more important than that of carbon steel, since stainless steel is primarily used to combat corrosion and even a small surface flaw can render the material liable to corrosion attack.

**Table 10.2** *Inspection methods for welds*

NDT type	Austenitic stainless steel	Duplex stainless steel	Carbon steel
Surface	Visual DPI	Visual DPI MPI	Visual DPI MPI
Volumetric	X-ray Gamma	X-ray Gamma	X-ray Gamma Ultrasonics

DPI – Dye penetrant inspection  
MPI – Magnetic particle inspection

Magnetic particle inspection is not an option for the austenitic steels since these are non-magnetic. Ultrasonic methods are of limited use on welds because of difficulties in interpretation; however, they can be used on parent material. Gamma radiography is not suitable for detecting cracking or lack of fusion in stainless steel materials less than 10 mm thick.

### 10.5 Galling and seizure

If surfaces are under load and in relative motion, galling may result from local adhesion and rupture of the surfaces. In some cases weld bonding and seizure may result. The following methods may be used to avoid galling problems:

- Use dissimilar standard grades of stainless steel (grades which differ in composition, work hardening rate and hardness) For example use grade A2-C2, A4-C4 or A2-A4 bolt-nut combinations from EN ISO 3506



- In severe cases, use a proprietary high work-hardening stainless steel alloy for one component or apply a hard surface coating
- Use anti-galling agents.

Note that if dissimilar steels or coatings are used, it is necessary to ensure that the required corrosion resistance is obtained. Greasing bolts is beneficial but may result in contamination by dirt and can present problems for storage.

It is recommended that bolting material should be in the cold worked condition, property class 70 minimum (see Table 3.3). Bolting materials should not be used in the softened condition because of the propensity for galling. Using rolled as opposed to machined threads and avoiding the use of fine threads and tight fitting thread forms reduces the likelihood of galling.

## 10.6 Finishing

The surface finish of stainless steel is an important design criterion and should be clearly specified according to architectural or functional requirements. The finer the finish, the greater the cost. This is where precautions taken earlier in handling and welding will pay off. Initial planning is important in reducing costs. For instance, if a tube to tube weld in a handrail or balustrade is hidden inside an upright, there will be a reduced finishing cost and a significant improvement in the final appearance of the handrail.

The surface of the steel should be restored to its corrosion resisting condition by removing all scale and contamination. Pickling in an acid bath will loosen any scale, enabling it to be brushed off with a bristle brush, and also dissolve any embedded iron or carbon steel particles.

Abrasive treatments, such as grinding, finishing, polishing and buffing, produce unidirectional finishes and thus the blending of welds may not be easy on plates/sheets with normal rolled surfaces. A degree of experimentation may be required to determine detailed procedures to obtain a suitable finish.

Electrolytic polishing removes a thin surface layer. A range of finishes from dull to a bright lustre can be produced, depending largely on the initial surface of the material.

There are other finishing processes (electroplating, tumbling, etching, colouring, and surface blackening) but these would only rarely be used for structural stainless steel and so are not described here.

It is worth noting again that the surface should be free of contaminants in the assembled structure. Particular consideration should be given to the possibility of contamination arising from work on adjacent carbon steelwork, especially from grinding dust. Either the stainless steel should be protected by removable plastic film, or final cleaning after completion of the structure should be specified in the contract documents.



## **APPENDIX A   Correlation between stainless steel designations**

Table A.1. gives the correlations between EN 10088, German, UK, French, Italian, Swedish, Spanish and US designations.

**Table A.1** *Stainless steel designations - correlation between European and previous national standards*

Steel grade to EN 10088	Germany (DIN)		UK	France	Italy	Sweden	Spain		USA
	Name	No.					AFNOR	UNI	
X5CrNi18-10	X5 CrNi 18 10	1.4301	304 S 15 304 S 16 304 S 31	Z 6 CN 18-09	X5 CrNi 18 10	2332 2333	3504	304	S 30400
X2CrNi19-11	X2 CrNi 19 11	1.4306	304 S 11	Z 2 CN 18-10	X2 CrNi 18 11	2352	3503	304 L	S 30403
X2CrNi18-9	-	-	-	-	-	-	-	-	-
X6CrNiTi18-10	X6 CrNiTi 18 10	1.4541	321 S 31	Z 6 CNT 18-10	X6 CrNiTi 18 11	2337	3523	321	S 32100
X5CrNi Mo17-12-2	X5CrNiMo 17 12 2	1.4401	316 S 31	Z 6 CND 17-11	X5 CrNiMo 17 12	2347	3534	316	S 31600
X2CrNiMo17-12-2	X2CrNiMo 17 13 2	1.4404	316 S 11	Z 2 CND 17-12	X2 CrNiMo 17 12	2348	3533	316L	S 31603
X2CrNiMo17-12-3	-	-	-	-	-	-	-	-	-
X2CrNiMo18-14-3	X2 CrNiMo 18 14 3	1.4435	316 S 13	Z 2 CND 17-13	X2 CrNiMo 17 13	2353	3533	316 L	S 31603
X1NiCrMoCu25-20-5	X1 NiCrMoCuN 25 20 5	1.4539	-	Z 1 CNDU 25-20	-	2562	-	904 L	N 08904
X6CrNiMoTi17-12-2	X6 CrNiMoTi 17 12 2	1.4571	320 S 31	Z 6 CNDT 17-12	X6 CrNiMoTi 17 12	2350	3535	316 Ti	S 31635
X2CrNiN18-10	X2 CrNiN 18 10	1.4311	304 S 61	Z 2 CN 18-10 Az	-	2371	-	304 LN	S 30453
X2CrNiMoN17-11-2	X2 CrNiMoN 17 12 2	1.4406	316 S 62	Z 2 CND 17-12 Az	-	-	-	316 LN	S 31653
X2CrNiMoN17-13-5	X2 CrNiMoN 17 13 5	1.4439	-	-	-	-	-	317 LMN	S 31726
X1NiCrMoCuN25-20-7	X1 NiCrMoCuN 25 20 6	1.4529	-	-	-	-	-	-	-
X2CrNiN18-7	X2 CrNiN 18 7	1.4318	-	-	-	-	-	301 LN (302 LN)	-
X2CrNiMoN22-5-3	X2 CrNiMoN 22 5 3	1.4462	Duplex 2205	Z 2 CND 22-5 Az	-	2377	-	-	S 31803

## APPENDIX B Lateral-torsional buckling

### B.1 General Case

The elastic critical moment for lateral-torsional buckling,  $M_{cr}$ , for a beam of uniform cross-section, is given by:

$$M_{cr} = C_1 \frac{\pi^2 EI_z}{(k_z L)^2} \left( \left[ \left( \frac{k_z}{k_w} \right)^2 \frac{I_w}{I_z} + \frac{(k_z L)^2 GI_t}{\pi^2 EI_z} + (C_2 z_g - C_3 z_j)^2 \right]^{1/2} - (C_2 z_g - C_3 z_j) \right)$$

where:

$C_1$ ,  $C_2$  and  $C_3$  are factors depending on loading and end restraint conditions, see Tables B.1 and B.2.

$I_t$  is the torsion constant

$I_w$  is the warping constant

$I_z$  is the second moment of area about minor axis

$k_z$  and  $k_w$  are effective length factors

$L$  is the length of beam between points which have lateral restraint

$z_g = z_a - z_s$

$z_a$  is the co-ordinate of point of load application

$z_s$  is the co-ordinate of the shear centre

$$z_j = z_s - \frac{\int z (y^2 + z^2) dA}{2 I_y}$$

In evaluating  $z_j$ ,  $z$  is negative for the compression flange;  $z_j$  is positive when the flange with the larger value of  $I_z$  is in compression at the point of largest moment. Note that  $z_j = 0$  for any equal flanged section including channels and z-shapes.

For gravity loads  $z_g$  is negative for loads applied above the shear centre. In the general case,  $z_g$  is negative for loads acting towards the shear centre from their point of load application. Note that if the load is restrained from moving sideways with the beam then  $z_g = 0$ .

The effective length factors  $k_z$  and  $k_w$  vary from 0,5 for full fixity to 1,0 for no fixity, with 0,7 for one end fixed and one end free. The normal conditions of restraint at each end are:

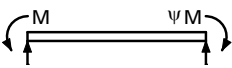


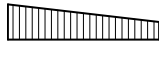






$$k_z = k_w = 1,0$$

- restrained against lateral movement, free to rotate on plan

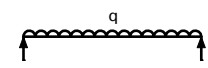

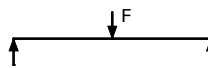
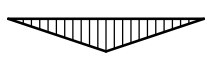
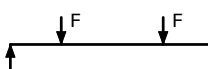

- restrained against rotation about the longitudinal axis, free to warp

The factor  $k_z$  refers to end rotation on plan. It is analogous to the ratio  $l/L$  for a compression member. The factor  $k_w$  refers to end warping. Unless special provision for warping fixity is made,  $k_w$  should be taken as 1,0.

**Table B.1** Values of factors  $C_1$  and  $C_3$  corresponding to values of effective length factor  $k_z$ : End moment loading

End moments and support conditions	Bending moment diagram	Value of $k_z$	Values of factors			
			$C_1$	$C_3$		
				$\psi_f \leq 0$	$\psi_f > 0$	
	 $\psi = +1$	1,0	1,00	1,000		
		0,5	1,05	1,019		
	 $\psi = +\frac{3}{4}$	1,0	1,14	1,000		
		0,5	1,19	1,017		
	 $\psi = +\frac{1}{2}$	1,0	1,31	1,000		
		0,5	1,37	1,000		
	 $\psi = +\frac{1}{4}$	1,0	1,52	1,000		
		0,5	1,60	1,000		
	 $\psi = 0$	1,0	1,77	1,000		
		0,5	1,86	1,000		
	 $\psi = -\frac{1}{4}$	1,0	2,06	1,000	0,850	
		0,5	2,15	1,000	0,650	
	 $\psi = -\frac{1}{2}$	1,0	2,35	1,000	$1,3 - 1,2\psi_f$	
		0,5	2,42	0,950	$0,77 - \psi_f$	
	 $\psi = -\frac{3}{4}$	1,0	2,60	1,000	$0,55 - \psi_f$	
		0,5	2,57	0,850	$0,35 - \psi_f$	
 $\psi = -1$	1,0	2,60	$-\psi_f$	$-\psi_f$		
	0,5	2,45	$0,125 - 0,7\psi_f$	$-0,125 - 0,7\psi_f$		

**Table B.2** Values of factors  $C_1$ ,  $C_2$  and  $C_3$  corresponding to values of effective length factor  $k_z$ : Transverse loading cases

Loading and support conditions	Bending moment diagram	Value of $k_z$	Value of factors		
			$C_1$	$C_2$	$C_3$
		1,0	1,12	0,45	0,525
		0,5	0,97	0,36	0,478
		1,0	1,35	0,59	0,411
		0,5	1,05	0,48	0,338
		1,0	1,04	0,42	0,562
		0,5	0,95	0,31	0,539

Note that Tables B.1 and B.2 may be used only for the case of monosymmetrical I profiles for which  $-0,9 \leq \psi_f \leq 0,9$

where:

$$\psi_f = \frac{I_{fc} - I_{ft}}{I_{fc} + I_{ft}}$$

in which:

$I_{fc}$  is the second moment of area of the compression flange about the minor axis of the cross-section

$I_{ft}$  is the second moment of area of the tension flange about the minor axis of the cross-section

$\psi_f = 0$  for bi-symmetric cross-sections

$\psi_f > 0$  for mono-symmetric cross-sections when the larger flange is in compression

$\psi_f < 0$  for monosymmetric cross-sections when the smaller flange is in compression

The following approximations for  $z_j$  can be used:

$$z_j = 0,8\psi_f \frac{h_s}{2} \quad \text{when } \psi_f \geq 0$$

$$z_j = \psi_f \frac{h_s}{2} \quad \text{when } \psi_f < 0$$

where:

$h_s$  is the distance between the shear centres of the flanges.

## B.2 Specific Cases

### B.2.1 Bi-symmetric cross-sections

The elastic critical moment for lateral torsional buckling of a beam of uniform symmetrical cross-section with equal flanges,  $z_j=0$ :

$$M_{cr} = C_1 \frac{\pi^2 EI_z}{(k_z L)^2} \left( \left[ \left( \frac{k_z}{k_w} \right)^2 \frac{I_w}{I_z} + \frac{(k_z L)^2 GI_t}{\pi^2 EI_z} + (C_2 z_g)^2 \right]^{1/2} - C_2 z_g \right)$$

For end-moment loading and transverse loads applied at the shear centre  $C_2 z_g=0$ . For these cases:

$$M_{cr} = C_1 \frac{\pi^2 EI_z}{(k_z L)^2} \left[ \left( \frac{k_z}{k_w} \right)^2 \frac{I_w}{I_z} + \frac{(k_z L)^2 GI_t}{\pi^2 EI_z} \right]^{1/2}$$

For normal conditions of restraint at each end,  $k_z=k_w=1,0$ :

$$M_{cr} = C_1 \frac{\pi^2 EI_z}{L^2} \left[ \frac{I_w}{I_z} + \frac{L^2 GI_t}{\pi^2 EI_z} \right]^{1/2}$$



## APPENDIX C Material data for deflection calculations

The secant modulus,  $E_S$ , to be used in deflection calculations (see Section 5.4.6) should be ascertained for the member with respect to the rolling direction. If the orientation is not known, or cannot be ensured, then the value for the longitudinal directions should be used.

The value of the secant modulus may be obtained as follows:

$$E_S = (E_{S1} + E_{S2})/2$$

where:

$E_{S1}$  is the secant modulus corresponding to the stress in the tension flange

$E_{S2}$  is the secant modulus corresponding to the stress in the compression flange.

Values of the secant moduli  $E_{S1}$  and  $E_{S2}$  for the appropriate orientation and serviceability design stress can be estimated from the following equation using the constants given in Table C.1. Alternatively, values for grades 1.4301, 1.4401 and 1.4462 may be taken from Table C.2 using linear interpolation as necessary.

$$E_{S,i} = \frac{E}{1 + 0,002 \frac{E}{\sigma_{i,Ed,ser}} \left( \frac{\sigma_{i,Ed,ser}}{f_y} \right)^n} \quad \text{and } i = 1,2$$

where:

$\sigma_{i,Ed,ser}$  is the serviceability design stress in the tension or compression flange

$E = 200\,000 \text{ N/mm}^2$ .

As a simplification, the variation of  $E_S$  along the length of the member may be neglected and the minimum value of  $E_S$  for that member (corresponding to the maximum values of the stresses  $\sigma_1$  and  $\sigma_2$  in the member) may be used throughout its length.

**Table C.1** Values of constants to be used for determining secant moduli

Grade	$f_y$ N/mm <sup>2</sup>	$n$	
		Longitudinal direction	Transverse direction
1.4301	210	6,0	8,0
1.4307	200		
1.4541	200		
1.4318	330		
1.4401	220	7,0	9,0
1.4404	220		
1.4571	220		
1.4362	400	5,0	5,0
1.4462	460		

**Table C.2** Secant moduli for deflection calculations for grades 1.4301, 1.4401 and 1.4462

Stress ratio ( $\sigma/f_y$ )	Secant modulus (kN/mm <sup>2</sup> )				
	Grade 1.4301		Grade 1.4401		Grade 1.4462
	Longitudinal direction	Transverse direction	Longitudinal direction	Transverse direction	Either direction
0,00	200	200	200	200	200
0,20	200	200	200	200	200
0,25	200	200	200	200	199
0,30	199	200	200	200	199
0,35	199	200	199	200	197
0,40	198	200	199	200	196
0,42	197	199	198	200	195
0,44	196	199	197	199	194
0,46	195	199	197	199	193
0,48	194	198	196	199	191
0,50	192	198	194	199	190
0,52	190	197	193	198	188
0,54	188	196	191	197	186
0,56	185	195	189	197	184
0,58	183	194	187	195	182
0,60	179	192	184	194	180
0,62	176	190	181	192	177
0,64	172	187	178	190	175
0,66	168	184	174	188	172
0,68	163	181	170	185	169
0,70	158	177	165	181	165
0,72	152	172	160	177	162
0,74	147	167	154	172	159
0,76	141	161	148	166	155

## PART II – DESIGN EXAMPLES

This section gives thirteen design examples that illustrate the application of the design rules. The examples are:

### ***Design example 1***

A circular hollow section subject to axial compression.

### ***Design example 2***

A welded I-beam with a Class 4 cross-section subject to combined axial compression and bending.

### ***Design example 3***

Trapezoidal roof sheeting with a Class 4 cross-section subject to bending.

### ***Design example 4***

A welded hollow section joint subject to fatigue loading.

### ***Design example 5***

A welded joint.

### ***Design example 6***

A bolted joint.

### ***Design example 7***

A plate girder with a Class 4 cross-section subject to bending. Shear buckling is critical.

### ***Design example 8***

A plate girder with a Class 4 cross-section subject to bending. Resistance to transverse loads is critical.

### ***Design example 9***

A cold formed channel subject to bending with intermediate lateral restraints to the compression flange. Lateral torsional buckling between intermediate lateral restraints is critical.

### ***Design example 10***

A rectangular hollow section subject to combined axial compression and bending with 30 minutes fire resistance.

### ***Design example 11***

Trapezoidal roof sheeting with a Class 4 cross-section subject to bending – a comparison of designs with cold worked material and annealed material.

### ***Design example 12***

A lipped channel from cold worked material in an exposed floor subject to bending.

***Design example 13***

A stainless steel lattice girder from cold worked material subject to combined axial compression and bending with 30 minutes fire resistance.

The plate girders in examples 7 and 8 are from duplex grade 1.4462. The members in the other examples are from austenitic grades 1.4301 or 1.4401.

The references in the margin of the design examples are to text sections and expressions/equations in this publication, unless specifically noted otherwise.